

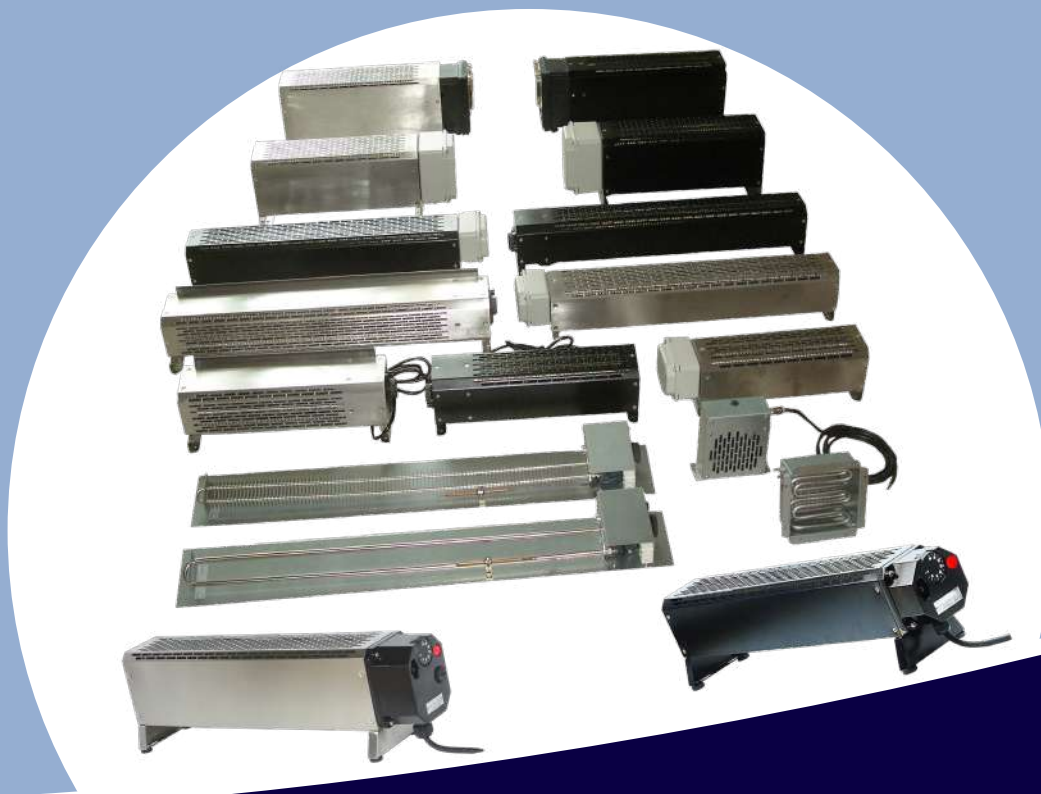

# ULTIMHEAT

---

## HEAT & CONTROLS



## AIR HEATING SOLUTIONS

- Flow through liquid heaters for incorporation:
- Flexible heating elements in silicone:

See catalogue No.23







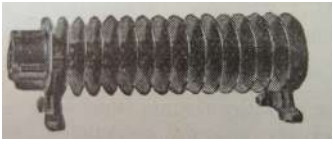

See catalogue No.25

Contact us





Because of permanent improvement of our products, drawings, descriptions, features used on these data sheets are for guidance only and can be modified without prior advice

Section 1	Summary			P1-P2
Section 2		Historical and technical introduction		P1-P16
Section 3	Reference list			P1-P4
<b>Air heating elements for incorporation</b>				<b>P1-P10</b>
Section 4		9SR	<b>Bracket mounting sheathed tubular heaters</b> , load 1.2W/cm <sup>2</sup> or 3W/cm <sup>2</sup> , dia. 10mm tube, for natural convection heating, or forced air heating.	P3
		9SX	<b>Finned tubular heaters, for incorporation</b> , with M14 threaded fitting, load 3W/cm <sup>2</sup> and 4.5W/cm <sup>2</sup> , for natural or forced convection heating.	P4
		9MN	<b>High emissivity infrared radiant heaters</b> , silicon carbide black body, high corrosion and mechanical resistance, large emissivity range from 3 to 6µm. Diameters 12, 14, 17, 20mm. Average load 3W/cm <sup>2</sup> . Surface temperature 400 to 450°C@25°C	P5-P6
		9NN	<b>Compact air duct heaters</b> , conduit for incorporation, from 400 to 1200W	P7
		9NF	<b>Medium power duct heaters, stainless steel finned heating elements.</b> With built in single pole high limit manual reset capillary thermostat. Electrical connection inside IP65 aluminum connection box.	P8
		9SQ	<b>Sub-assemblies for home convection heating remodeling.</b> For incorporation. With temperature control adjustable thermostat, high limit disc thermostat, illuminated switch.	P9
		9SY	<b>Finned tubular heater sub-assemblies for home heating remodeling.</b> For incorporation. With temperature control adjustable thermostat, high limit disc thermostat, illuminated switch	P10



Commercial and industrial convection radiators				P1-P14
Section 5		9PF	<b>Cabinet fan heaters,</b> - remote control thermostat - built-in fixed setting control thermostat - built-in adjustable control thermostat	P3-P4
		9CG1	<b>Enclosed finned tubular heaters, 110mm compact range.</b> Painted steel or stainless steel frame. Wall or floor installation. Without fans. With built in single pole high limit manual reset capillary thermostat. Without temperature control. Electrical connection inside IP65 epoxy painted aluminum connection box.	P5
		9CG3	<b>Enclosed finned tubular heaters, 130mm range.</b> Painted steel or stainless steel frame. Wall or floor installation. Without fans. With built in single pole high limit manual reset capillary thermostat. Without temperature control. Electrical connection inside IP65 epoxy painted aluminum connection box.	P6
		9CH	<b>Fan heaters with controls, 110mm compact range.</b> Painted steel or stainless steel frame. Wall or floor installation, IP40. With adjustable thermostat, switch and high limit capillary thermostat.	P7
		9CL	<b>Convectors with fans and controls, downward air flow protected against vertical water drops.</b> Stainless steel frame only. Wall installation. IP44. With adjustable thermostat, tempORIZED fans switch-off, high limit capillary thermostat and main switch.	P8
		9CJ	<b>Fan heater, thermostat control, 130mm range.</b> Painted steel or stainless steel frame. Wall or floor installation. PA66 control box, with sealable window access. Thermostat and high limit controls. IP40. 3 fans. Available in IP65, without fans.	P9-P10
		9CK	<b>Convectors with fans, electronic control. 130mm range.</b> Painted steel or stainless steel frame. Wall or floor installation. PA66 control box, with sealable window access. Electronic temperature control and electromechanical high limit capillary thermostat. IP40. 3 fans. Available in IP65 without fans	P11-P12
		9CR	<b>Downward blowing fan heaters with thermostatic control, 130mm range, protected against vertical water drops.</b> Stainless steel or painted steel frame. Wall installation. PA66 control housing, window access. High limit manual reset capillary thermostat. IP44, 3 fans	P13
		9CS	<b>Downward blowing fan heaters with electronic control, 130mm range, protected against vertical water drops.</b> Stainless steel or painted steel frame. Wall installation, PA66 control housing, window access. High limit manual reset capillary thermostat. IP44	P14

Because of permanent improvement of our products, drawings, descriptions, features used on these data sheets are for guidance only and can be modified without prior advice





Because of permanent improvement of our products, drawings, descriptions, features used on these data sheets are for guidance only and can be modified without prior advice

Waterproof industrial radiators				P1-P4
Section 6		9CA	<b>Small industrial electric baseboard heaters</b> , natural convection, width 110mm, IP69K (high pressure hot water) waterproof grade, IK10 shockproof grade, with 1 or 2 finned heating elements, 600W and 1200W.	P3
		9CB	<b>Industrial electric baseboard heaters</b> , natural convection, width 130mm, IP69K (high pressure, hot water) waterproof grade, IK10 shockproof grade, with 3 or 6 finned heating elements, 1750W and 3500W.	P4
Infrared heaters				P1-P4
Section 7		9MH	<b>Infrared radiant heater, 110mm compact range.</b> Painted steel or stainless steel frame. Wall or hanged mounting, IP40. With switch. Far infrared (3 to 6 μm) silicon carbide heating tube, 20 mm dia. High reflectivity aluminum parabolic reflector, ventilated.	P3
Controls for air heating				P1-P12
Section 8		Y22 Y038G Y02N	<b>Thermostats for air heating control, convection heating applications</b>	P3-P5
		Q7C	<b>Humidistat for cabinet heaters</b>	P6
		3AE	<b>Power control for convection heating</b>	P7
		Y24 Y038H	<b>Thermostats for air heating control, infrared heating applications</b>	P8-P9
		3AS 3AY	<b>Power control for infrared heating</b>	P10-P11

Update 2025/02/25



Because of permanent improvement of our products, drawings, descriptions, features used on these data sheets are for guidance only and can be modified without prior advice



Because of permanent improvement of our products, drawings, descriptions, features used on these data sheets are for guidance only and can be modified without prior advice

# **Section 2**

## **Summarized history of air heating and sheathed heating elements**



Because of permanent improvement of our products, drawings, descriptions, features used on these data sheets are for guidance only and can be modified without prior advice



## Summarized history of air heating and sheathed heating elements

The invention of sheathed heating elements comprising a metal tube swaged around a coiled heating wire, and which is insulated by compressed magnesia, was an essential step of the electrothermics development. Thanks to their mechanical strength, impermeability and resistance to corrosion, these are the most professional heating technical solutions. The appearance of these heating elements, now universally used, was the result of a combination of different advanced techniques of the early 20<sup>th</sup> Century.

Over the last two decades of the 19<sup>th</sup> Century, the emergence of electric heating had revealed the need to find reliable solutions for converting electricity into heat. The first electrical heaters were platinum wires (inherited laboratory equipment), nickel silver or even iron. Research carried on resistive elements with greater resistivity and good temperature resistance.

On October 12, 1878, St. George Lane Fox-Pitt filed patent in England 4043, in which he developed the use of electricity for lighting and heating. This patent, based on the use of platinum filaments, was not followed for heating but it was the basis for the development of electric bulbs.



1895 Ferronickel (Ultimheat Museum document)

In 1884, French Henri Marbeau, a pioneer in the manufacture of Nickel in New Caledonia and France, founded the company "Le Ferro-Nickel" in Lizy sur Ourcq. He became the first to obtain sufficiently pure alloys of iron and nickel, which nickel content was mastered, to be used as heating wires. These alloys (patented in 1884 and 1888) with different proportions of nickel were set forth at the Paris Exhibition of 1889. Their temperature resistance and resistivity were incommensurate with wires used previously.

Between 1888 and 1890, the exponential growth of incandescent lamps, which carbon filament supports are made of platinum causes the tripling of the price of this material in 2 years, from 900 to 2,750 francs per kg, which made it too expensive for heating applications.

**Ironically, carbon, rapidly dropped for incandescent lamps, now returns in the form of braided fibers in the quartz tube heating elements radiating in the shortwave infrared.**

From 1890, heating wires embedded in an asbestos board were used for irons (Carpenter, USA).

The electric furnace set forth in 1891 by the Austrian Friedrich Wilhelm Jenny Schindler still uses platinum heating wires embedded in an insulating enamel. It will be presented at the Chicago World's Fair in 1893.

In 1891, the English manufacturer R.E.B. Crompton presents at the London Exhibition at the Crystal Palace, a frying pan and other electrical heating devices (which will be shown in a catalog in 1894 «Domestic Electric Machinery, Electrical Heating and Cooking Electrical Apparatus») in which the heating element is a copper zigzag wire embedded in the enamel forming the bottom of the pan. It quickly turned out that the heating wires broke quickly because the expansion coefficient of the enamel was lower than that of the metal plate it was layed on. In the same year, a similar solution used by the Carpenter Electric Company (St. Paul, Minesotta) on electric kettles experienced the same troubles.

Because of permanent improvement of our products, drawings, descriptions, features used on these data sheets are for guidance only and can be modified without prior advice



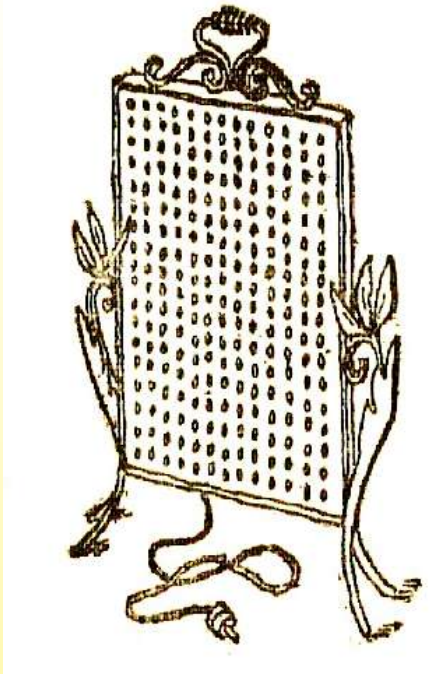

Crompton electric heater  
(ca1895, Ultimheat Museum document)



1898 electric cooker by Grimm, Schindler-Jenny  
patent (Ultimheat Museum document)

At the same time in Switzerland, the company Grimm & Co. develops a similar range of products under license from the Austrian Schindler-Jenny and Stuz, which will be presented at the Chicago Exposition in 1893. The maximum temperature reached is 250°C then, because it is limited by the performance of insulating enamels.

In 1893, the Scottish Alan MacMasters in Edinburgh, proposed to perform the first Crompton toaster using bare heating wires made of iron. This device, called "Eclipse" and produced around 1894 was a commercial failure, because the heating wires used to melt.

By 1894, the Vaudeville Theatre, London, was the first public place to be heated with electric heaters. But at this time, electric heaters were already commonly used to heat the trams because electricity was already available. Heating wires used to be made of galvanized steel or nickel silver also called «German silver».

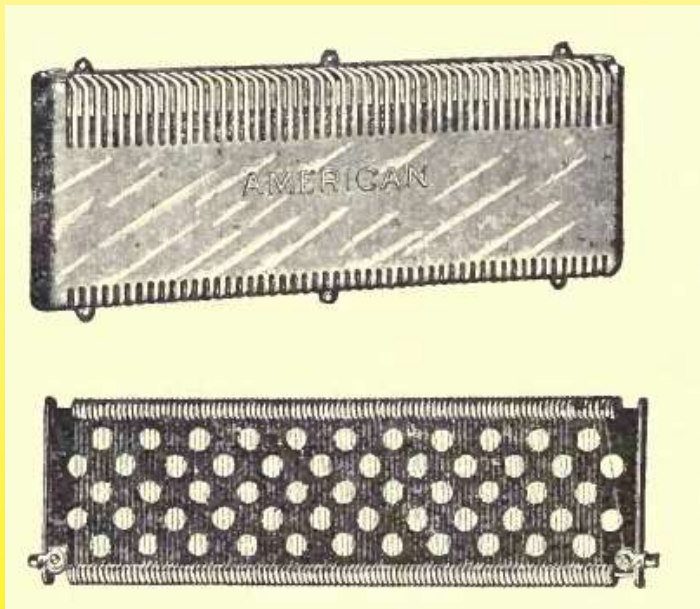

1895 Tramway heater, made of nickel silver wires stretched between porcelain insulating parts (extract from "Electric heating", by Edwin J. Houston and A. E. Kennelly, 1895)



Extract from the electrical devices in the Guise Familistère range in 1897 (Ultimheat Museum document)

The technique of enameled heating wire is applied in France for the first electrical appliances of the Familistère de Guise (Dequenne), presented in their 1897 catalog, under Crompton license, at the Universal Exhibition of 1900, which uses nickel silver wires and then ferronickel wires. The enamel technology has evolved and breakages are less common.

Because of permanent improvement of our products, drawings, descriptions, features used on these data sheets are for guidance only and can be modified without prior advice



Because of permanent improvement of our products, drawings, descriptions, features used on these data sheets are for guidance only and can be modified without prior advice

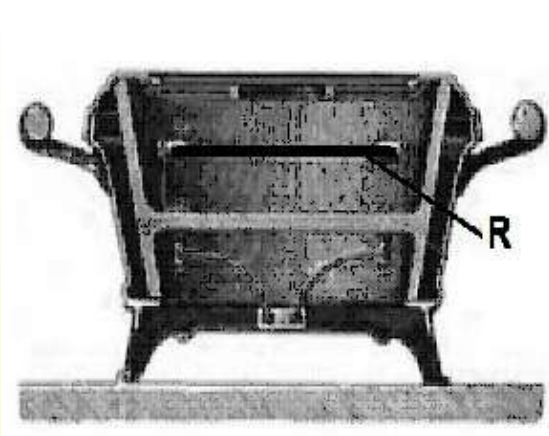

1899 Parvillée's metal ceramic heating element  
(Ultimheat Museum document)

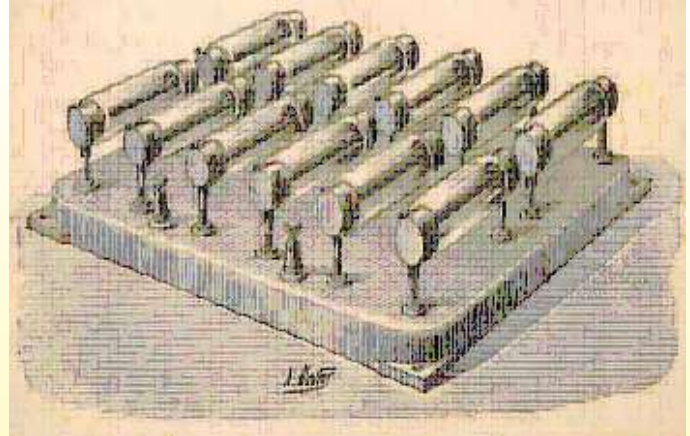

1898 Le Roy's electric hot logs  
(Ultimheat Museum document)

From 1899, the French company "Parvillée Frères et Cie" patented and manufactured high-power heating elements made of metal ceramic sintered (nickel, quartz and kaolin base), running red outdoors, paving the way for the first electric heating and cooking professional devices, shown in operation in the La Feria restaurant at the Universal Exhibition of Paris in 1900.

**These elements may be considered as the ancestors of the heating elements made of silicon carbide, currently used in industrial furnaces.**

In 1898, the French Le Roy used a 100 × 10 × 3 mm "graphitoïde silicon" bar surrounded by a glass envelope in which there is vacuum, as a heating element, in order to produce 80 watts hot logs.

This element resistivity is 230,000 times greater than the nickel silver wire, and withstands 800 ° C. These hot logs will be used for twenty years.

Around 1902-1903, the ferronickel heating wire gradually replaces the nickel silver wire in applications requiring high operating temperatures. The ferronickel heating wires are wound on a ceramic, asbestos or mica core, or sandwiched between two enamel layers.

The quick development of domestic appliances (irons, water heaters, room heaters), and the demand for heating wires and better systems tickled manufacturers research, particularly in the USA, which was at the forefront of household electrification.



1923 Ad for Nichrome wire  
(Ultimheat Museum document)

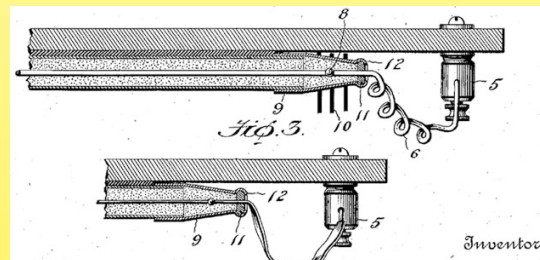

1914 Wiegand patent, straight heating element insulated with magnesia in a tube

In March 1905, the American engineer Albert Leroy Marsh at Hoskins Manufacturing Co. in Detroit made an important discovery for the heating elements: A 80% nickel and 20% chromium alloy, which is later named Nichrome, which resistivity, corrosion resistance and temperature resistance allow the making of reliable and durable heaters. (U.S. Patent No. 811,859, February 1906). This alloy Nichrome 80/20, withstanding continuous 900-1000°C temperatures, essential to radiate in the infrared, allowed to make heating elements incandescent in the air. At this time, no material but platinum which was too expensive, would allow to meet this need.

It allowed to make the first electric toaster with bare resistances or in quartz tubes in 1908 (Radiant heaters in quartz tube, patented January 12, 1908 by William S Andrews). These heating elements under radiant quartz tube will be the ancestors of the quartz tubes used in infrared heating and in radiant cooking stoves.

In January 1914, Edwin L. Wiegand young American engineer filed several patents related to mass production of iron heating elements. for the soles of irons, he invented heating wires positioned in a «cement or pressed powder» heat conductor. This was the origin of the company Chromalox in Pittsburgh, which then began mass production of these heating elements for irons.

On January 3, 1914, he filed, among other things, a patent for a tubular element comprising a straight heating wire, insulated with magnesia (patent US1127374).



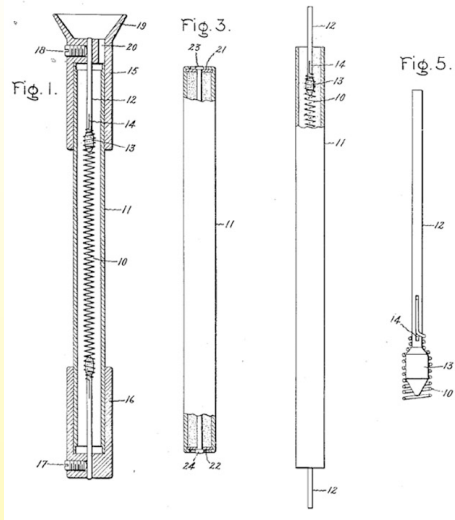

1918 Charles Abbott's patent

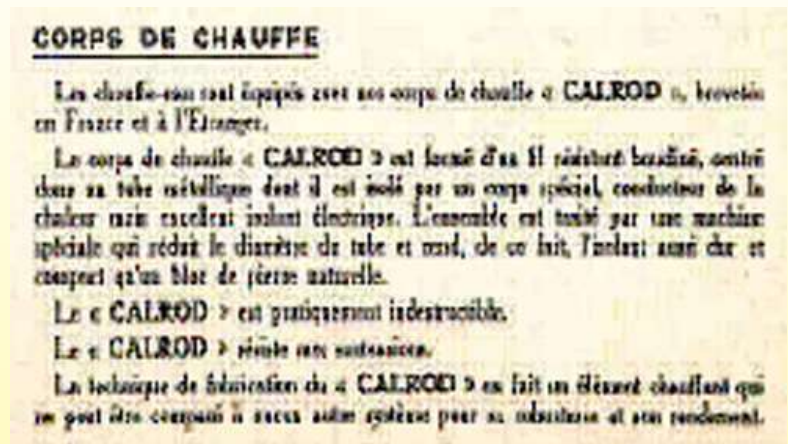

1932 Calrod product description in the Als-Thom catalogue (Ultimheat Museum document)

On November 15, 1918, Charles Abbott, Pittsfield, Massachusetts, Engineer for General Electric USA, filed the 1.367341 Patent, where wire wound heating elements surrounded by magnesia are compressed by necking of the tube. These heating elements will be known under the brand name «Calrod», also called in France «shielded heating elements» and marketed by Thomson (Als-Thom) around 1930.

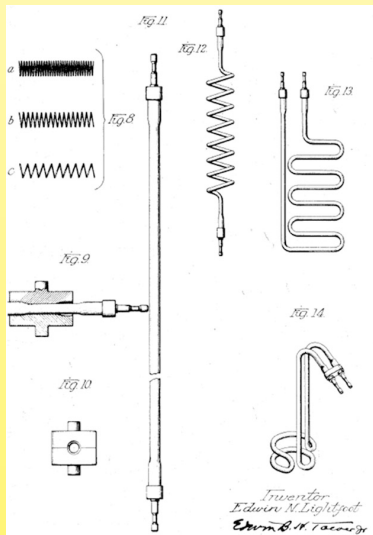

1920 Edwin Lightfoot's patent

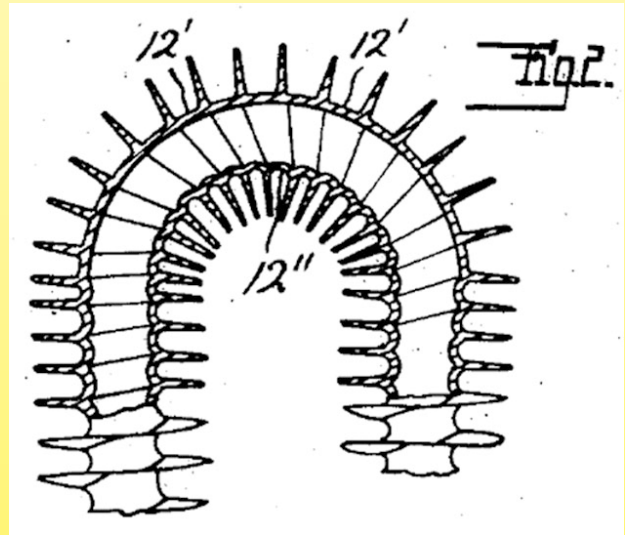

1930 Charles Paugh's patent

On June 22, 1920, Edwin N. Lightfoot, of company Cutler Hammer, filed the US1359400 patent, which describes the contemporary shielded elements, their forming possibilities, the rolling methods, and an automatic filling machine which principle is still used nowadays.

On December 16, 1921, the Norwegian Christian Bergh Backer invented a system for producing magnesia by oxidation of magnesium metal by steam under pressure. In this method, as the later Backer called «Conversion Process», it is no longer the compression of the metal tube which compresses magnesia, but magnesia is produced directly in the tube. This oxidation produces magnesium hydroxide which volume is twice the original metal volume. The hydroxide is then converted by heating into magnesium oxide, which is both an electrical insulator and a thermal conductor (Norwegian Patent 37862, U.S. Patent 1,451,755 granted on 17/04/1923, last update 16340). Despite the loss of electrical insulation due to the conversion of hydroxide into oxide in this system (which were offset by subsequent modifications of the method in 1936), these two production systems, Calrod and Backer will compete for decades. But only the Calrod process has survived, thanks to its simplicity of manufacture as a self evidence.

These two systems will allow the production of shielded heating elements with high power densities, which will be limited only by the maximum possible temperature of the internal heating wire and by the tube capacity to exchange its own heat with the external environment.

In the case of heating a liquid, the liquid itself will limit its thermal conductivity and its flow speed, corresponding to its thermal capacity. In the case of air, it quickly became obvious that the exchange surface of the tube should be increased to take advantage of the high power densities achievable. Therefore, both ways were explored: Helical fins on tubes that are then formed or fins crimped on pin shape tubes.



## Historical and technical introduction

On June 16, 1930, Charles Paugh of the Wolverine Tube Company, filed a patent (Patent US1909005 A) for a method of producing added fins on metal tubes, allowing subsequent tube bending.

These helical fins were quickly used for central heating radiators, and the manufacturing technique was easily transposed to shielded heating elements.

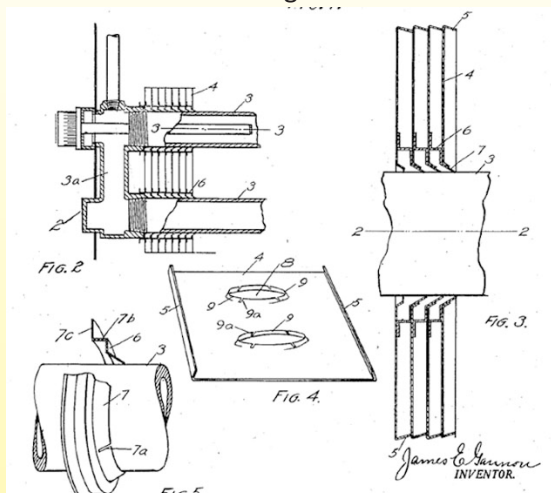

1927 James Gannon's patent

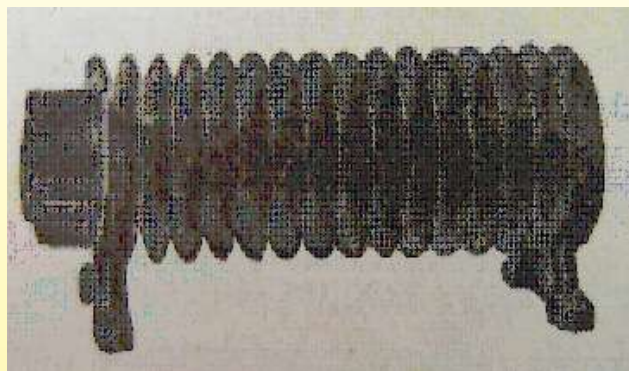

1932 Radiator using Als-Thom's spiral coil fin heaters (Ultimheat Museum document)

On December 8, 1927 James E. Gannon, American Electric Heating Company, introduced the first electric heater using rectangular fins crimped onto a shielded hairpin heater element (Patent US1788516 A).

Technical developments since the 1930s have mainly focused on improving the quality of magnesia powders, of resistive wires, and in the appearance of metal tubes with high heat and corrosion resistances (among other materials: 304, 321, 316 stainless steel and Incolloy 800, 840, 825).

The arrival of Iron Chrome Aluminum alloys in 1931, invented by Hans Von Kantsow in Sweden (who founded the company Kanthal, acronym of his name and Aluminum), allowed the making of heating wires with an even higher temperature resistance than Nickel Chromium and resistant to corrosion. These wires have now become a standard of high temperature resistance.

**NOUVEAUTÉS DU SALON MÉNAGER 1939**

**APPAREILS ÉLECTRO-DOMESTIQUES THOMSON**

**BOUILLIÈRES AU CALROD**

Les bouillières THOMSON sont composées d'une cuve, en métal chromé ou en porcelaine, dans laquelle plonge un élément CALROD inoxydable, aisément détachable.

Cette nouvelle formule de construction comporte de nombreux avantages :

- Réserve de chauffe DOUBLÉE.
- Nettoyage à grande eau possible.
- Robustesse et sécurité : le CALROD est indestructible, même fonctionnant à sec.
- Hygiène et propreté de la cuve PORCELAINE.
- Possibilité d'employer les deux cuves (métal et porcelaine) avec un seul élément : DEUX BOUILLIÈRES presque au prix d'une.
- GRANDE CAPACITÉ : 1 litre 3/4 (1,750 l.), mais faculté de chauffer les plus petites quantités de liquide.

Bouillière 650 W cuve chromée . . . . . 225, »  
 Bouillière 650 W cuve porcelaine . . . . . 165, »  
 (Autres modèles 950 W : voir catalogue.)

1939 Calrod heating elements made of Stainless Steel (Ultimheat Museum document)

After a period of prohibition to use electricity for heating, imposed in 1941, several manufacturers of shielded elements such as Métanic, Rubanox, Spirox, were born in France from 1945.

Technology and research then carried on sealing the ends of the tubes, because the hydrophilic properties of magnesia make it slowly lose its insulating properties. The development of silicone resins (1945-1950) and epoxy resins (1955-1957) greatly improved this critical point.

Since that time, there was little change in the concept of manufacturing shielded heating elements and improvements appeared mainly in the quality of raw material, and of new refractory and stainless alloys used for metal tubes and heating wires.

The evolution and democratization of devices for making sintered silicon carbide elements, as well as quartz tubes and bars helped make infrared radiant elements with a very high yield.

Because of permanent improvement of our products, drawings, descriptions, features used on these data sheets are for guidance only and can be modified without prior advice



Because of permanent improvement of our products, drawings, descriptions, features used on these data sheets are for guidance only and can be modified without prior advice



Because of permanent improvement of our products, drawings, descriptions, features used on these data sheets are for guidance only and can be modified without prior advice

# Useful technical tables for air heating



Because of permanent improvement of our products, drawings, descriptions, features used on these data sheets are for guidance only and can be modified without prior advice





Figures provided in this section are results of tests made in our laboratory. Charts were smoothed by computer, and are given for specified power and for information only.

## Type 3AY

Estimated life expectancies for magnesium oxide insulated heater types made in stainless steel or refractory alloys.



Surface temperature		Time (years)	Time (hours)	Surface temperature		Time (years)	Time (hours)
°C	°F			°C	°F		
700	1300	23	200.000	980	1800	0.15	1200
760	1400	9	80.000	1040	1900	0.01	360
815	1500	3.5	30.000	1095	2000	-	180
870	1600	1	8700	1150	2100	-	48
925	1700	0.3	3000				

For a standard sheathed element, the surface temperature of 870°C (1600°F) is the maximum temperature to insure expected heater life greater than one year. These values are for information only, and data are provided for heating elements using Nickel Chrome alloy wires whose cross section is optimized, and which are insulated with good quality pure magnesia, not contaminated. This deterioration of heating wires at temperatures well below their melting point is due to chemical reactions that occur at high temperature between the iron oxide (which is a contaminant of magnesia), and the wire itself.

Note: When the sheathed elements are used in medium infrared radiant heating, this temperature of 870°C (1600°F) is generally exceeded if the surface load is equal to or greater than 10W/cm<sup>2</sup> (60W/in<sup>2</sup>). This is the main reason of the short life expectancy of these heaters in this application.

## Average surface temperature and average air temperature of air heaters described in this catalogue Temperature cycles of some tables are due to built-in temperature controls.

Figures provided in this section are results of tests made in our laboratory. Charts were smoothed by computer, and are given for specified power and for information only.

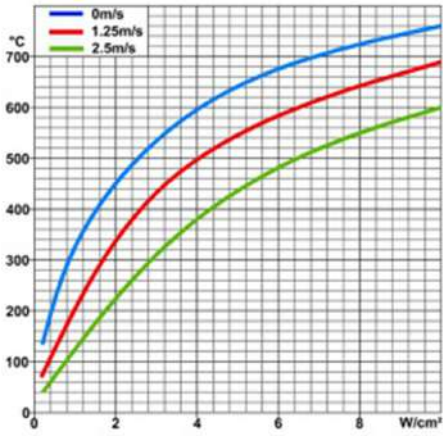
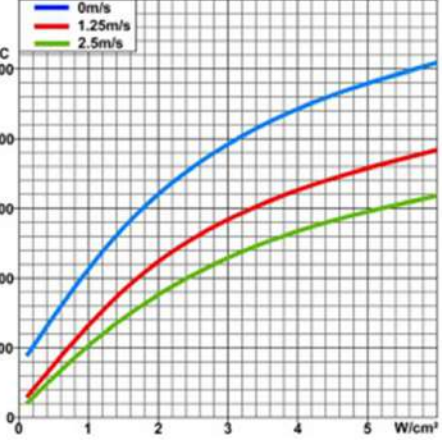
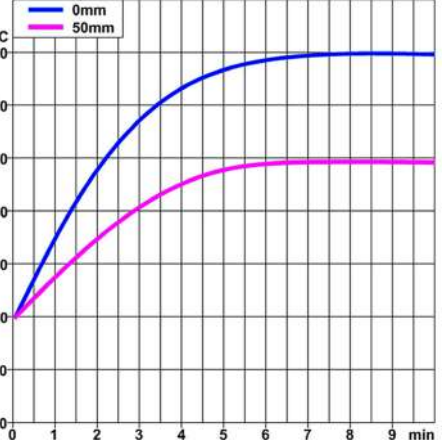





9SR, P3 of section 4	9SX, P4 of section 4	9NN, P7 of section 4, 400W
		
		
Surface temperature of a dia. 10 mm stainless steel sheathed tubular heating element, VS surface load, in still air, and in ventilated air. (RT=20°C)	Surface temperature of a stainless steel finned heater, 25 x 50 mm fins, VS surface load, in still air, and in ventilated air. (RT=20°C)	Surface temperature of a compact duct heater, and temperature measured at 50mm from the air outlet grid, air speed 2m/s.

Because of permanent improvement of our products, drawings, descriptions, features used on these data sheets are for guidance only and can be modified without prior advice

# Useful technical tables for air heating

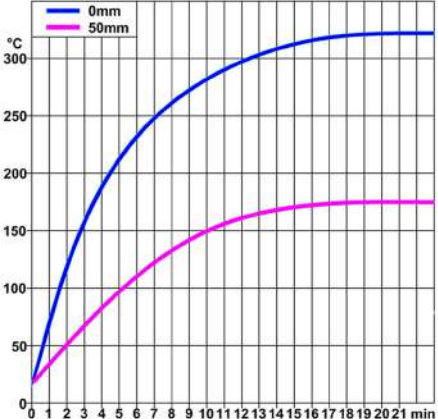
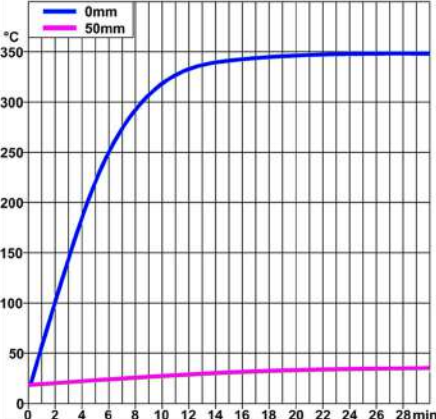
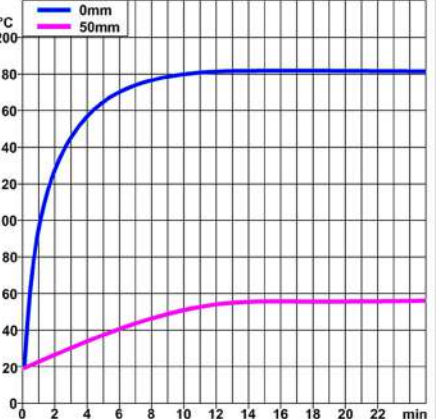

Because of permanent improvement of our products, drawings, descriptions, features used on these data sheets are for guidance only and can be modified without prior advice

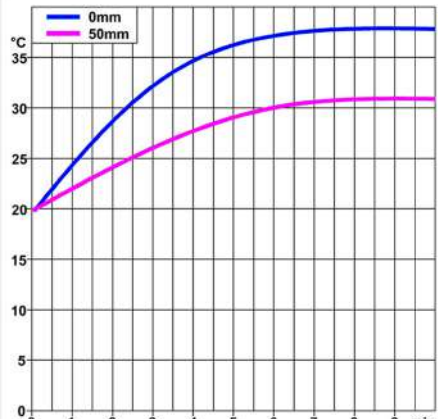
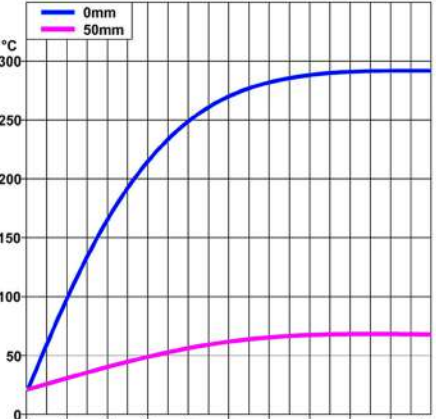
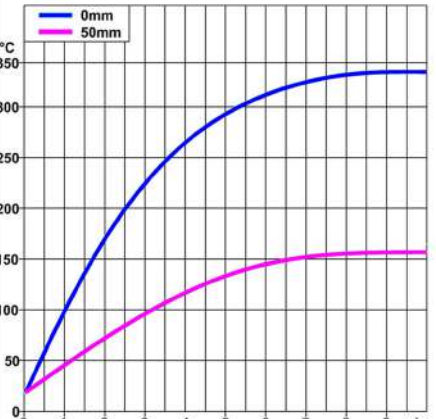
<p>9NF, P8 of section 4, 4000W</p>	<p>9SQ, P9 of section 4, 500W</p>	<p>9SY, P10 of section 4, 1050W</p>
		
		
<p>Fins surface temperature of a medium power duct heater, and temperature measured at 50mm from the fins, air speed 2m/s.</p>	<p>Surface temperature of remodeling sheathed heater, and temperature measured at 50mm from the sheathed element, natural convection.</p>	<p>Surface temperature of remodeling finned sheathed heater, and temperature measured at 50mm from the fins, natural convection.</p>
<p>9PF, P3 of section 5, 100W</p>	<p>9CG1, P5 of section 5, 3000W</p>	<p>9CG3, P6 of section 5, 4000W</p>
		
		
<p>Surface temperature of cabinet heater, and temperature measured at 50mm from the air outlet grid, air speed 2m/s</p>	<p>Outlet grid surface temperature of enclosed finned heater, and temperature measured at 50mm from the air outlet grid, natural convection</p>	<p>Outlet grid surface temperature of an enclosed finned heater, and temperature measured at 50mm from the air outlet grid, natural convection.</p>



# Useful technical tables for air heating



Because of permanent improvement of our products, drawings, descriptions, features used on these data sheets are for guidance only and can be modified without prior advice

<p>9CH, P7 of section 5, 3000W</p>	<p>9CL, P8 of section 5, 1500W</p>	<p>9CJ, P9 of section 5</p>
<p>Outlet grid surface temperature of an enclosed finned fan heater, with thermostat control, and temperature measured at 50mm from the air outlet grid, air speed 1m/s.</p>	<p>Outlet grid surface temperature of an enclosed finned fan heater, downward blowing, with thermostat control, and temperature measured at 50mm downside the air outlet grid, air speed 1m/s.</p>	<p>Outlet grid surface temperature of an enclosed finned fan heater, with thermostat control, and temperature measured at 50mm from the air outlet grid, air speed 2m/s.</p>
<p>9CK, P11 of section 5, 4000W</p>	<p>9CR, P13 of section 5</p>	<p>9CS, P14 of section 5, 4000W</p>
<p>Outlet grid surface temperature of an enclosed finned fan heater, with electronic control, and temperature measured at 50mm from the air outlet grid, air speed 2m/s.</p>	<p>Outlet grid surface temperature of an enclosed finned fan heater, downward blowing, with thermostat control, and temperature measured at 50mm downside the air outlet grid, air speed 2m/s.</p>	<p>Outlet grid surface temperature of an enclosed finned fan heater, downward blowing, with electronic control, and temperature measured at 50mm downside the air outlet grid, air speed 2m/s.</p>



## Indicative power selection chart of cabinet heaters (Non insulated metal cabinets)

Power upon cabinet outside surface (ft<sup>2</sup>) and requested delta of temperature between inside and outside. Plastic cabinets: Divide by 2. Outdoor vented area: add 50%

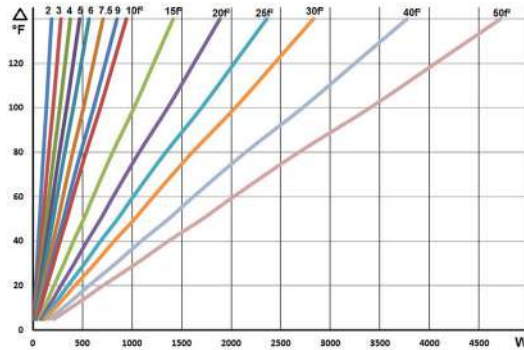

Power upon cabinet outside surface (m<sup>2</sup>) and requested delta of temperature between inside and outside. Plastic cabinets: Divide by 2. Outdoor vented area: Add 50%

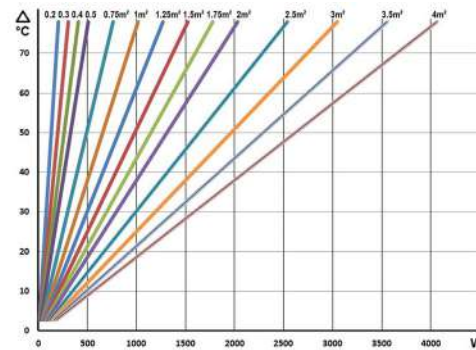

## Infrared wavelengths

Infrared heater surface temperature VS wavelength

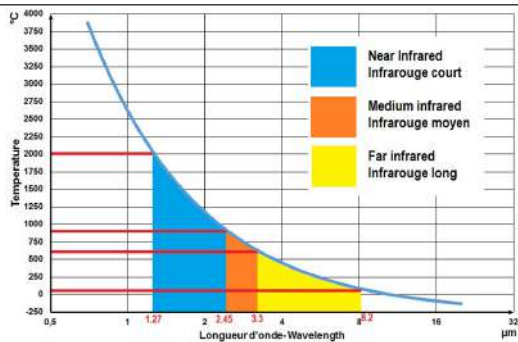

Response time of different far infrared heaters (temperature stabilized at 440°C), compared to response time of a medium infrared heater (temperature stabilized at 700°C).

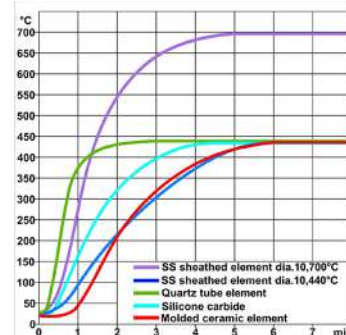

There are many definitions of infrared and its division into far (long), medium and near (short), and often confusion is made between these different definitions.

- The first is that of astronomy, according to ISO 20473 which defines the infrared radiation from the red edge of the visible spectrum at 0.780 micrometers (microns) up to 1000 microns.

- The second is that of the CIE recommends that in the field of photobiology and photochemistry, cutting the infrared range into three zones: IR-A: 0.7 microns to 1.4 microns; IR-B: of 1,4 microns to 3 microns; IR-C: 3 microns to 1000 microns.

- The third, used in the field of infrared heating, defined wavelengths as follows (see table below):

- **Far infrared**, from 370 to 600°C, corresponding to a wavelength of 4.5 to 3.30µm.

However, there are infrared emitters called «low temperature infrared» for space heating (heating ceilings, wall heating for saunas, convectors called «radiant» heaters), which operate at lower surface temperatures of about 70 to 80°C corresponding to wave lengths from 8.2 to 7.8 microns.

- **Medium Infrared**, 600 to 900°C corresponding to a wavelength of 3.3 to 2.45µm

- **Near Infrared**, 900 to 2,000°C, corresponding to a wavelength of 2.45 to 1.27µm.

### Far Infrared Emitters.

- Infrared ceramic heater made of a ceramic encapsulated wire. The surface temperature of the ceramic may range from 350°C to 650°C. Because of their design and the low thermal conductivity of the ceramic used, differences in temperature up to 200°C on the emissive surface between bumps and groves, center and edges are possible. The resulting infrared radiation is distributed over a large wavelength range. In addition, a large percentage of the radiation emitted on the rear face of such elements, only serves to heat their support.

The ceramics used to make these elements have a low emissivity in the far infrared, so, an additional percentage of the energy is dissipated in the different wavelengths. To overcome it, some of them are now covered with a black glaze. The time to reach 90% of their operating temperature, starting from 25°C is approximately 5 minutes 40s.)

- Sintered silicon carbide tube emitters: they reach an emissivity close to 100% in the 3 to 4 microns wavelength, corresponding to 450 - 690°C (840-1280°F) surface temperature. The time to reach 90% of their operating temperature, starting from 25°C is about 3 minutes 30 seconds.

- Sheathed tubular elements: usually consisting of a tube made of Inconel, specially oxidized to give it a better infrared emissivity. The tube surface gives a dark red visible radiation. Their surface temperature range from 450 to 600°C. The time to reach 90% of their operating temperature, starting from 25°C is about 5 minutes 30 seconds for a 10mm dia. tub. (About the same time than a ceramic radiant heater)

Because of permanent improvement of our products, drawings, descriptions, features used on these data sheets are for guidance only and can be modified without prior advice





Because of permanent improvement of our products, drawings, descriptions, features used on these data sheets are for guidance only and can be modified without prior advice

## Medium infrared emitters

They come in two main forms:

- Quartz tube elements, in which a wire coil, made of chromium nickel, carbon, iron-nickel-chromium or tungsten, is placed in a milky surface quartz tube. These tubes are open at both ends, and in contact with atmospheric air. They have a surface temperature of 700°C to 1000°C; Particularly economical, but fragile, with a limited life of about 5000 hours for the heating wire reaching high temperatures in air where they are quickly oxidized.

The time to reach 90% of the operating temperature, measured from 25°C is approximately 1minute 20s

- Tubular sheathed elements, similar to those used in the far infrared. The high surface load gives a visible red light. The surface temperature of these components is in the range of 700°C to 800°C.

The time to reach 90% of the operating temperature, measured from 25°C is approximately 2 minutes 40s

## Near (Short) Infrared emitter

This radiation source is constituted by an incandescent tungsten or Iron-Chromium-Aluminum filament in a quartz tube filled with nitrogen or argon and, optionally, depending on the model, a small percentage of halogen gas. The filament is heated to an average temperature of 1800°C. (Some up to 2500°C). Originally developed for applications in lighting, they emit a portion of their radiation in the far infrared, as a part of the emitted wavelengths in the visible spectrum and in the near infrared is absorbed by the quartz and converted in far infrared by the silica-oxygen chemical bond.

Their inertia is very low (a few seconds). These tubes must be cooled.

## The main types of infrared emitters

Materials are selective as to the wavelength accepted to absorb infrared energy. Most of materials show a peak of absorption between 3 and 4 microns (μm).

The wavelength produced by the heat source is dependent upon the source temperature. It is possible then to adjust the source temperature and thus the peak wavelength to match the best spectral absorption rate or wavelength. The formula providing surface temperature for a requested wavelength (μ) is:

$$^{\circ}\text{C} = (2897/\mu) - 273 \text{ or } ^{\circ}\text{F} = (5215/\mu) - 459$$

For example, if the product to heat has an absorption peak at 3.5μ, the heating element surface temperature should be:  $(2897/3.5) - 273 = 555^{\circ}\text{C}$ , or  $(5215/3.5) - 459 = 1031^{\circ}\text{F}$ .

This rule applies no matter what the construction of heat source.

Hence, filament bulb temperatures being very high, they will radiate in the near infrared, sheathed incolloy heaters with temperatures of 600 to 700°C will radiate in the mid Infrared, and ceramic heaters with 400 to 500°C surface temperature will radiate in the far infrared. What will make the difference in the final efficiency is the percentage of power supplied to the heating source that will be converted in the required wavelength.

This also means that it is possible to adjust the wavelength peak of a radiating source by controlling its surface temperature, e.g by adjusting the voltage or controlling the power, and mainly using heaters materials with the best emissivity in the requested wavelength.

Sintered silicon carbide tubes reach a radiance near 100% equivalent to a blackbody in the 3 to 4 micron zone corresponding to 450 - 690°C (840-1280°F) surface temperature.

## Thermal response of silicone carbide infrared heaters

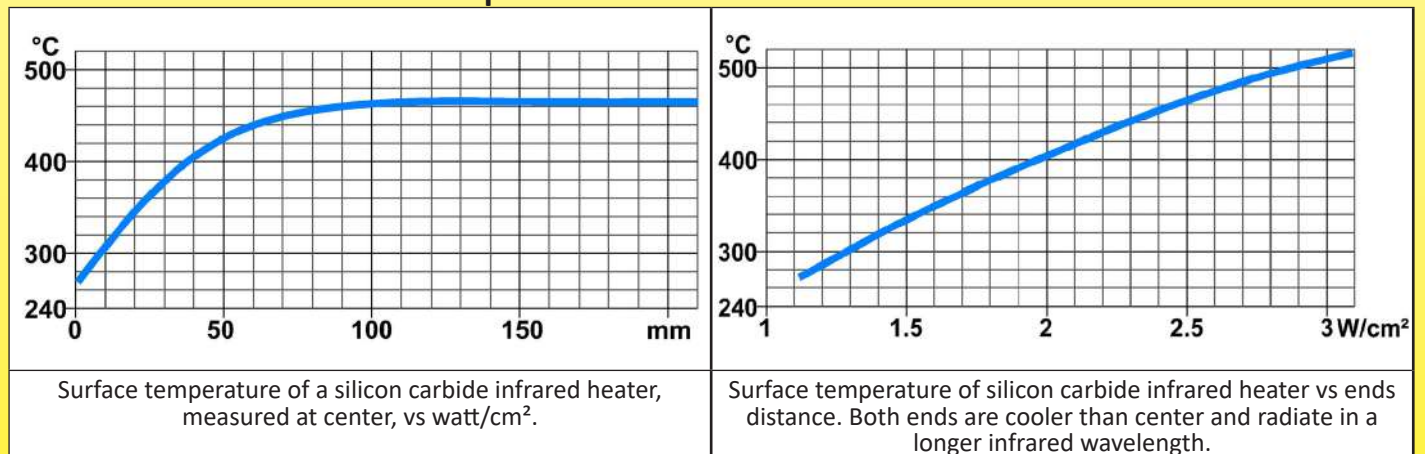

## Some Material Emissivity

Emissivity	Emissivity		Emissivity	Emissivity	
	Polished Surface	Black Oxided		Polished Surface	Black Oxided
Aluminum	0.09	0.22	Incoloy 800	0.20	0.92
Brass	0.04	0.60	Inconel 600	0.20	0.92
Copper	0.04	0.65	Sintered Silicone oxide,	N.A	0.93
Stainless 304,316, 321	0.17	0.85	Blackbody	N.A	1.00



## Absorption peak of some materials (μm)

Absorption peaks are wavelengths that are the most converted in energy inside the material and will result in its heating.

Absorption peaks of infrared radiations	Material						
	Water	Aluminum	Linen, cotton	Concrete	Silk	Plaster	Porcelain
Main peak wavelength(μ)	3	3	3	3	3	3	5
Secondary peak wavelength (μ)	6	8.5	6.5	6.5	5	6	8
	Flint, Crystal	Polyethylene	Plexiglass	PVC	Polystyrene	Magnesium oxide	Rubber
Main peak wavelength(μ)	8	3.5	6	3.5	3.5	3.5	3.5
Secondary peak wavelength (μ)	N/A	7	9	7	7	6	8

## Temperature of food products heated by infrared emitter

Tests carried out by subjecting a 30mm thickness sample of synthetic material (methylcellulose gel) having a UV behavior close to food. Test made from different distances, by measuring the sample temperature at 10mm deep. Tests were made with silicone carbide infrared heaters 9MH described P3 of section 7 in this catalog. The distance is measured from the edge of the reflector to the surface of the sample. Sample temperature is 20°C at the start of the test.

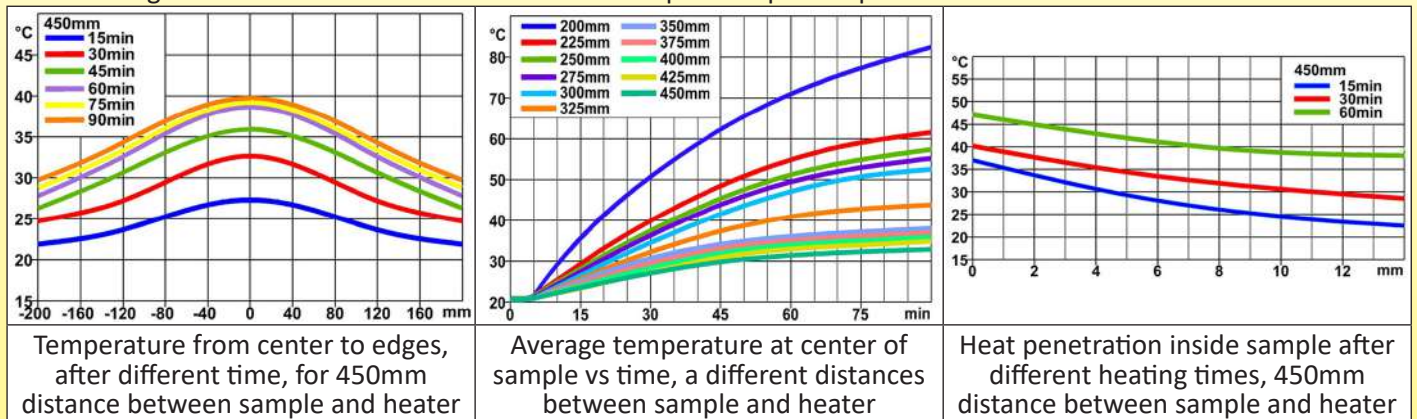



# Section 3

## References list



Because of permanent improvement of our products, drawings, descriptions, features used on these data sheets are for guidance only and can be modified without prior advice

# References list



Because of permanent improvement of our products, drawings, descriptions, features used on these data sheets are for guidance only and can be modified without prior advice

References	References	References	References
3AER101TF230V	9CJ34Y33023200H4	9MNPA20H23B255D0	9SRC900A23A1650A
3AER102TF024V	9CJ34Y33023200HB	9NFL170C230753NC	9SXC175A232103C3
3AER102TF048V	9CJ34Y63023300H4	9NFL170C231506NC	9SXC175A233103C3
3AER104TF400V	9CJ34Y63023300HB	9NFL320C231503NC	9SXC300A234003C3
3AER105TF110V	9CJ34Y6304330004	9NFL320C233006NC	9SXC300A236003C3
3ASN30100110	9CJ34Y630433000B	9NFL420C232103NC	9SXC415A233503C3
3ASN30100120	9CJ3DY23023260HB	9NFL420C234206NC	9SXC415A238503C3
3ASN30700110	9CJ3DY32023130H4	9NNL128423400BJ0	9SXC500A237003C3
3ASN30700120	9CJ3DY32023130HB	9NNL128G23400BJ0	9SXC500A23A053C3
3AYM30100125	9CJ3DY62023260H4	9NNL188423600BJ0	9SXC750A23A073C3
3AYN30100125	9CJ3DY6204326004	9NNL188423600BJC	9SXC750A23A603C3
3AYN30100140	9CJ3DY620432600B	9NNL188G23600BJ0	9SXA00A23A503C3
3AYN30100160	9CK34Y33023200H4	9NNL188G23600BJC	9SXA00A23B203C3
3AYN30700125	9CK34Y33023200HB	9NNL368423A20BJ0	9SYL12GA223170EC
3AYN30700140	9CK34Y63023300H4	9NNL368G23A20BJ0	9SYL24GA123085EC
3AYN30700160	9CK34Y63023300HB	9PF1058L423005EC	9SYL24GA223250EC
9CAR7S12023060EB	9CK34Y6304330004	9PF1058L523020EC	9SYL36GA123125EC
9CAR7S12023060EH	9CK34Y630433000B	9PF1058LG23005EC	Q7C0301001001R00
9CAR7S22023120EB	9CK3DY23023260HB	9PF1058LH23020EC	Y02NAC000060114P
9CAR7S22023120EH	9CK3DY32023130H4	9PF1108L423010EC	Y02NAC005035114L
9CAV7S12023060EB	9CK3DY32023130HB	9PF1108L523040EC	Y02NAC005035114P
9CAV7S12023060EH	9CK3DY62023260H4	9PF1108LG23010EC	Y02NAC020080114L
9CAV7S22023120EB	9CK3DY6204326004	9PF1108LH23040EC	Y02NAC020080114P
9CAV7S22023120EH	9CK3DY620432600B	9PF2058L423005EC	Y02NAC-10050114L
9CBS7T32023175H4	9CL14033023150H4	9PF2058L523020EC	Y02NAC-10050114L
9CBS7T32023175HB	9CL14033023150HB	9PF2058LG23005EC	Y02NAC-10050114P
9CBS7T62023350H4	9CL17033023300H4	9PF2058LH23020EC	Y036GA004040QB3J
9CBS7T62023350HB	9CL17033023300HB	9PF2108L423010EC	Y036GA004040QB3K
9CBT7T62040350H4	9CR34Y33023200H4	9PF2108L523040EC	Y038GA004040AA3K
9CBT7T62040350HB	9CR34Y33023200HB	9PF2108LG23010EC	Y038GA004040AO6J
9CBX7T32023175H4	9CR34Y63023300H4	9PF2108LH23040EC	Y038GA004040AO6K
9CBX7T32023175HB	9CR34Y63023300HB	9PF3058L423005EC	Y038GA004040QO3J
9CBX7T62023350H4	9CR34Y6304330004	9PF3058L523020EC	Y22D9J00806USUSA
9CBX7T62023350HB	9CR34Y630433000B	9PF3058LG23005EC	Y22D9K01006USUSA
9CBX7T62040350H4	9CS34Y33023200H4	9PF3058LH23020EC	Y22D9K02006USUSA
9CBX7T62040350HB	9CS34Y33023200HB	9PF3108L423010EC	Y22D9K03006USUSA
9CG13N23023150E4	9CS34Y63023300H4	9PF3108L523040EC	Y22D9K07006USUSA
9CG13N23023150EB	9CS34Y63023300HB	9PF3108LG23010EC	Y22D9L01006USUSA
9CG13N24523225E4	9CS34Y6304330004	9PF3108LH23040EC	Y23D7J03308C1C10
9CG13N24523225EB	9CS34Y630433000B	9SQL12GA123050EC	Y23D7J04010C1C10
9CG16N23023300E4	9MHP290H23052SF1	9SQL12GA223100EC	Y23D7J05010C1C10
9CG16N23023300EB	9MHP290H23052SR1	9SQL24GA123100EC	Y23D7J05510C1C10
9CG16N24523450E4	9MHP290H23052SS1	9SQL24GA223200EC	Y23D7J06010C1C10
9CG16N24523450EB	9MHP590H23110LF1	9SRC250A2316050A	Y23D7J07010C1C10
9CG34G33023200E4	9MHP590H23110LR1	9SRC250A2340050A	Y23D7Q04511C1C10
9CG34G33023200EB	9MHP590H23110LS1	9SRC400A2327550A	
9CG34G34523230E4	9MNPN200E232255A0	9SRC400A2367550A	
9CG34G34523230EB	9MNPN200H232375D0	9SRC500A2335050A	
9CG34G63023400E4	9MNPN280H235255D0	9SRC500A2387550A	
9CG34G63023400EB	9MNPN300E232340A0	9SRC600A2342550A	
9CG34G64523460E4	9MNPN400E232450A0	9SRC600A23A0550A	
9CG34G64523460EB	9MNPN400H237505D0	9SRC700A2350050A	
9CH14033023150H4	9MNPN500H239505D0	9SRC700A23A2550A	
9CH14033023150HB	9MNPN580H23A105D0	9SRC800A2357550A	
9CH17033023300H4	9MNPN800H23A505D0	9SRC800A23A1550A	
9CH17033023300HB	9MNPA00H23A905D0	9SRC900A2360050A	

Update 2025/02/25





Because of permanent improvement of our products, drawings, descriptions, features used on these data sheets are for guidance only and can be modified without prior advice



Because of permanent improvement of our products, drawings, descriptions, features used on these data sheets are for guidance only and can be modified without prior advice

---

# Section 4

## Air heating elements for incorporation



Because of permanent improvement of our products, drawings, descriptions, features used on these data sheets are for guidance only and can be modified without prior advice



# Air heating elements for incorporation

## Bracket mounting sheathed tubular heaters, dia. 10mm, for convection heaters or fan heaters

### Type 9SR

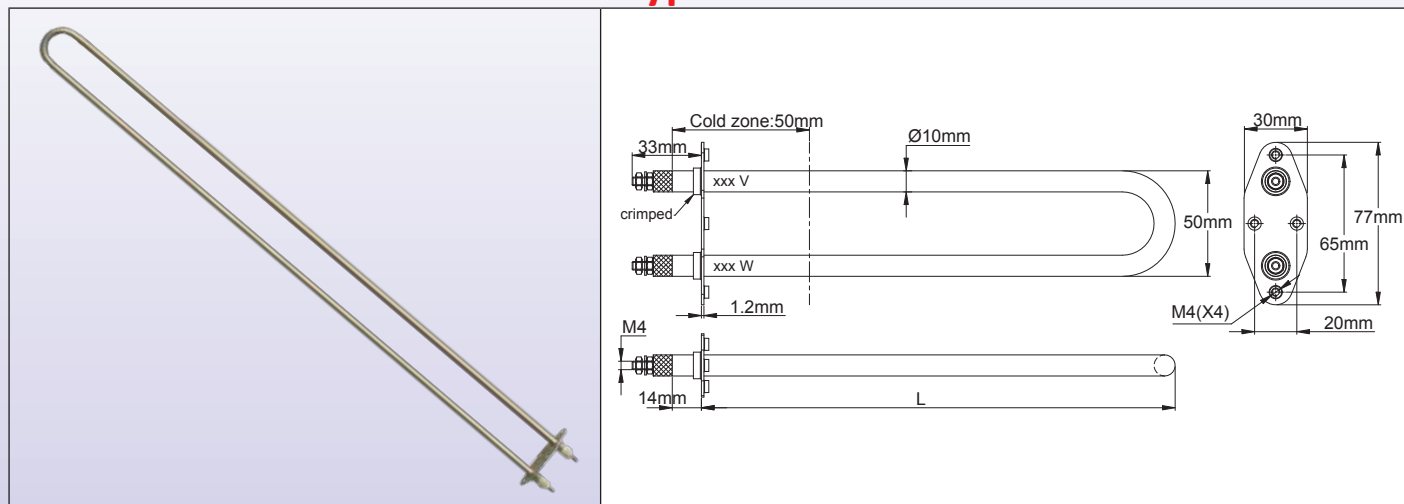

### Description

These U shape sheathed heaters, designed for professional OEM are crimped on a light stainless steel flange, and are easy to integrate through metal wall. They have an exceptional insulation resistance and outstanding humidity resistance. They are designed for heating of air by natural convection or fans

### Main Features

**Heating elements material:** 10mm dia. 304L stainless steel sheath. Optional: SS 201, 316, 321, or Incolloy 800.

**Connection:** M4 stainless steel terminals screws with stainless steel M4 nuts and stainless washer, ceramic bead output.

**Insulation resistance:** > 3 GOhms (new), and > 1 GOhms (after following climatic test):

1000 hours at 100°C followed by 1000 hours at 60°C and 95% relative humidity, followed by 90 cycles of one hour from -20°C to +70°C, followed by 240 hours at -30°C.

**Dielectric strength:** > 1800 volts, 0.2mA (100% tested in production) and after climatic tests carried out by sampling.

**Bracket:** Crimped, 304 stainless steel, 1.2 mm thickness, with 4 M4 threaded holes, distances 65mm and 20mm.

#### Surface load:

For safe use, we recommend a maximum surface load of 1.2 W/cm<sup>2</sup> (7.8 W/in<sup>2</sup>) for applications in natural convection (heating element surface temperature ~ 300°C), and 3 W/cm<sup>2</sup> (19.5 W/in<sup>2</sup>) for applications in forced convection (heating element surface temperature ~ 300°C for an air velocity ~ 2.5m/s).

See P11 of section 2 of this catalog tables providing surface temperatures and air temperature vs load with and without fans

**Voltage:** 230V. Other values on request

**Tolerances on power:** +5/-10%

**Options:** Other surface load, other lengths, metal or plastic junction box, thermostat control with housing, special brackets with one or more heating elements.

### Main references

1.2W/cm <sup>2</sup> (7.8W/in <sup>2</sup> )			3W/cm <sup>2</sup> (19.5W/in <sup>2</sup> )		
References	Length L (mm)	Power (W)	References	Length L (mm)	Power (W)
9SRC250A2316050A	250	160	9SRC250A2340050A	250	400
9SRC400A2327550A	400	275	9SRC400A2367550A	400	675
9SRC500A2335050A	500	350	9SRC500A2387550A	500	875
9SRC600A2342550A	600	425	9SRC600A23A0550A	600	1050
9SRC700A2350050A	700	500	9SRC700A23A2550A	700	1250
9SRC800A2357550A	800	575	9SRC800A23A1550A	800	1500
9SRC900A2360050A	900	650	9SRC900A23A1650A	900	1650



# Air heating elements for incorporation

**Finned tubular heaters, for incorporation, with M12 threaded fitting, load 3W/cm<sup>2</sup> and 4.5W/cm<sup>2</sup>, for convection heaters or fan heaters**  
**Type 9SX**

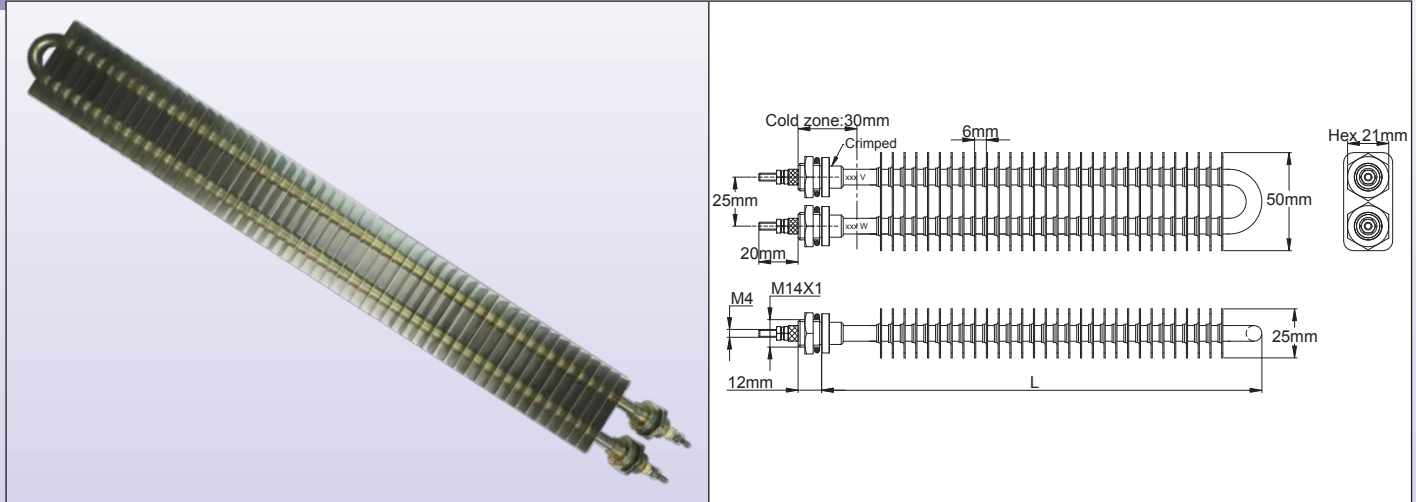

## Description

These U shape finned sheathed heaters, designed for professional OEM are crimped on a light stainless steel flange, and are easy to integrate through metal wall. **They have an exceptional insulation resistance and outstanding humidity resistance.** They are designed for heating of air by natural convection or fan.

## Main Features

**Heating element material:** 8mm dia. 304L stainless steel sheath. Optional: SS 201, 316, 321, or Incolloy 800.

**Fins size:** 25 × 50 mm, 25 mm distance between tube axis.

**Fins material:** SS304 (Zinc plated steel fins on request, MOQ apply)

**Connection:** M4 stainless steel terminal screws with stainless steel M4 nuts and stainless washer, ceramic bead output.

**Fittings:** Crimped, M14x1mm thread, in 304SS, with nickel plated brass nuts and fiber gaskets. Waterproof version with TIG welded fittings or economical version with nickel plated steel fittings are available on request (MOQ apply)

**Insulation resistance:** > 3 GOhms (new), and > 1 GOhms (after following climatic test):

1000 hours at 100°C followed by 1000 hours at 60°C and 95% relative humidity, followed by 90 cycles of one hour from -20°C to +70°C, followed by 240 hours at -30°C.

**Dielectric strength:** > 1800 volts, 0.2mA (100% tested in production) and after climatic tests carried out by sampling.

### Surface load:

For safe use, we recommend a maximum surface load of 3 W/cm<sup>2</sup> (19.5 W/in<sup>2</sup>) for applications in natural convection (heating element surface temperature ~ 300°C), and 4.5 W/cm<sup>2</sup> (30W/in<sup>2</sup>) for applications in fan heating (heating element surface temperature ~ 300°C for an air velocity ~ 2.5m/s).

**See P11 of section 2 of this catalog tables providing surface temperatures and air temperature vs load with and without fans**

**Voltage:** 230V. Other values on request

**Tolerances on power:** +5/-10%

**Options:** Other surface load, other lengths, metal or plastic junction box, wall mounting legs, nickel or zinc plated fins, or SS201 fins

## Main references

3W/cm <sup>2</sup> (19.5W/in <sup>2</sup> )			4.5W/cm <sup>2</sup> (30W/in <sup>2</sup> )		
References	Length L (mm)	Power (W)	References	Length L (mm)	Power (W)
9SXC175A232103C3	175	210	9SXC175A233103C3	175	310
9SXC300A234003C3	300	400	9SXC300A236003C3	300	600
9SXC415A233503C3	415	550	9SXC415A238503C3	415	850
9SXC500A237003C3	500	700	9SXC500A23A053C3	500	1050
9SXC750A23A073C3	750	1070	9SXC750A23A603C3	750	1600
9SXCA00A23A503C3	1000	1500	9SXCA00A23B203C3	1000	2200



# Air heating elements for incorporation

## Last generation of infrared tubular heaters, for assemblers

### Type 9MN

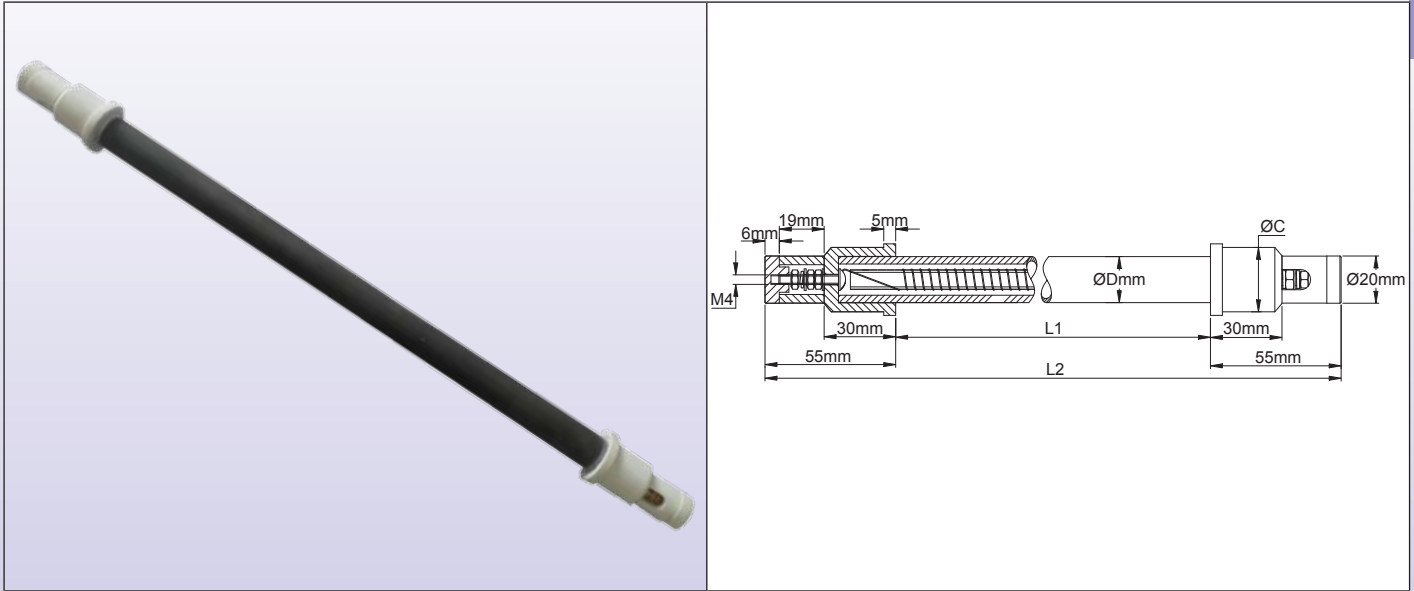

#### Main features

Designed to be used by assemblers, these tubes radiate in the infrared between 3 and 6 $\mu$ . They are characterized by an emissivity close to 100% within this range, they show a low surface temperature, a high mechanical strength, and high corrosion resistance.

They are particularly suited for heating, drying, or polymerization of a large part of usual materials where they heat faster than the traditional convection heating. It is recommended to install them on a reflector.

#### Applications

- Drying at low temperature leather, wood, prints and dyes, paints, ceramic email, food, fish.
- Varnish Polymerization on metal in automotive, appliances and similar industries
- Maintain temperature of products displayed or waiting in fast food and restaurants
- Heating of plastics before forming
- Sterilization of medical devices and equipment or food
- Outdoor ambient warming
- Reheating workstation in workshop
- Heating of stables, poultry

#### Specifications

##### RadiatingTube:

**Material:** Sintered silicon carbide, 3mm thickness.

**Corrosion resistance:** Higher than tungsten carbide and alumina, particularly at high temperature

**High mechanical resistance to bending in 3 points:** 550 MPa at room temperature (on 3 x 4 x 45mm rod)

**Low-thermal expansion:** 4.10-6 mm/MMK

**High thermal-conductivity at 200°C:** >100 W/mK

This high thermal conductivity guarantees outstanding temperature uniformity over the entire length of the tube, resulting in a well-focused wavelength of infrared radiation.

##### Heater assembly

##### **Insulation resistance:**

- Measured between outer tube and live part: >100Gohm (cold-state)
- Measured at 450°C between ceramic brackets and live parts: >20 Gohms

**High-pot insulation:** >2500V

**Outside standard diameters:** 12mm and 20mm. 14 and 17mm on request (MOQ apply)

**Power density:** 3 W/cm<sup>2</sup>. (Other values on request if the wavelength must be modified)

**Warm up time:** Less than 5 minutes (From room temperature to stabilization)

**Heater wire:** 80/20 Nickel Chrome wound on quartz rod

**Surface temperature:** 400 to 450°C @ 25°C.

**Electrical connections:** Screw-in ceramic cap, stainless steel M4 screws

**Mounting:** Both ends of the tubes have an alumina ceramic section for fixing by clamps

**Voltage:** 230V standard. Other voltages on request (MOQ apply)

**Options:** Several tubes grouped side by side on the same surface, or on a cylindrical surface to achieve radiant panels.

# Air heating elements for incorporation



## References for tubes with 12mm OD, loaded at 3W/cm<sup>2</sup>.

Overall length (L2)	Effective length (L1)	Mounting diameter (C)	Power (Watts)	Reference
310	200	19 mm	225	9MNP200E232255A0
410	300	19 mm	340	9MNP300E232340A0
510	400	19 mm	450	9MNP400E232450A0

## References for tubes with 20mm OD, loaded at 3W/cm<sup>2</sup>.

Overall length (L2)	Effective length (L1)	Mounting diameter (C)	Power (Watts)	Reference
310	200	27mm	375	9MNP200H232375D0
400*	280*	27mm	525	9MNP280H235255D0
510	400	27mm	750	9MNP400H237505D0
610	500	27mm	950	9MNP500H239505D0
700*	580*	27mm	1100	9MNP580H23A105D0
910	800	27mm	1500	9MNP800H23A505D0
1110	1000	27mm	1900	9MNPA00H23A905D0
1310	1200	27mm	2250	9MNPA20H23B255D0

\* For use in reflectors of products page 3 of section 7

Because of permanent improvement of our products, drawings, descriptions, features used on these data sheets are for guidance only and can be modified without prior advice





# Air heating elements for incorporation

## Small size air duct square heaters, for incorporation, 400 to 1200W Type 9NN

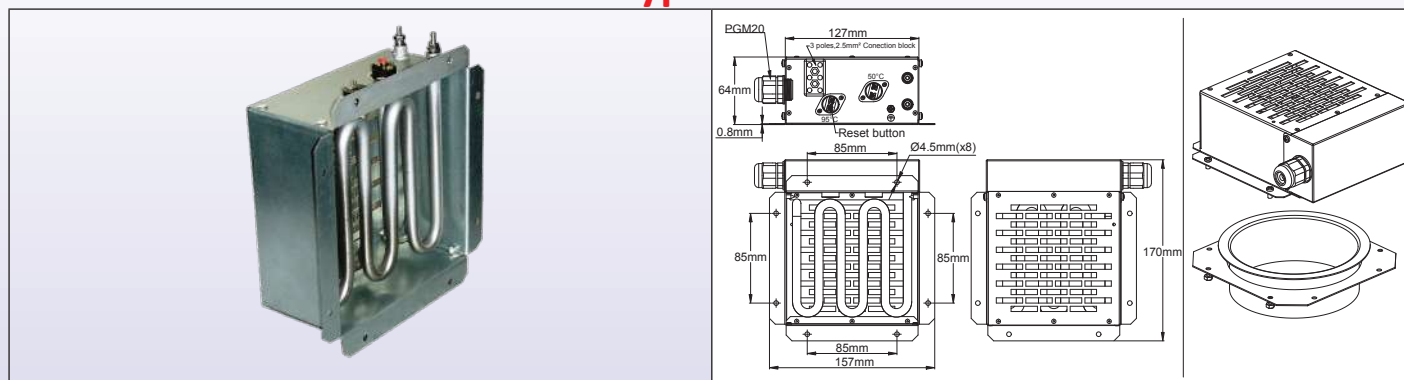

### Typical applications

Thin and compact air duct heaters, designed to be used in industrial or commercial air conditioning systems. Their design allows to mount them at the end of 125mm dia. air duct on existing circuits. One of their applications is to allow, without costly work, to boost air/air type heat pumps whose power is insufficient in extreme weather conditions. They are intended to be used by integrators in ventilated air ducts.

They are made of a stainless steel sheathed tubular heating element, mounted on an electro-galvanized steel or stainless steel frame. They can be supplied with or without electrical connection box.

They are supplied with 2 levels of temperature overheat protection.

### Main features

**Frame:** Galvanized steel sheet or 304 stainless steel

**Safety thermostat N°1:** Automatic reset, open at 50°C, reset at 40°C

**Safety thermostat N°2:** Open at 95°C. Manual reset

**Heating element:** 8mm diameter sheathed tubular heating element, stainless steel 304L. (Other features, see P3 of section 4)

**Power vs Heater surface loads and minimum flow \*:**

- For 400W the surface load is 1.2W/cm<sup>2</sup>, and minimum air velocity must be 0.5 m/s, i.e. a rate equal to or greater than 28m<sup>3</sup>/h in a dia. 125mm duct.

- For 600W the surface load is 1.8W/cm<sup>2</sup>, and minimum air velocity must be 1.5 m/s, i.e. a rate equal to or greater than 84m<sup>3</sup>/h in a dia. 125mm duct.

- For 1200W the surface load is 3.6W/cm<sup>2</sup>, and minimum air velocity must be 2.5 m/s, i.e. a rate equal to or greater than 140m<sup>3</sup>/h in a dia. 125mm duct.

\* Indicative values. Calculated so that the surface temperature of the heating elements does not exceed 300°C. It is up to the integrator to perform the appropriate checks on flow and temperatures reached in the application, so that they conform to the regulations and safety standards.

**Voltage:** 220/240V, 50/60Hz (110-120V on request)

**Connection box**(in models supplied with it): IP40 with M20 cable gland in PA66

**Connection:** Ceramic terminal block 3 × 2.5mm<sup>2</sup>

**Mounting:** On flat surface, with 8 screws. Also allows the mounting on a 125mm dia. metal duct with a collar lip diameter 144mm to 150mm. (See accessories hereunder)

**Options:** Other surface load, other thermostat set point temperatures (MOQ apply)

### Main references

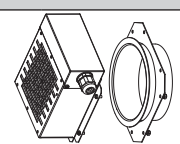
References with zinc plated steel enclosure	References with SS304 enclosure	Power (W)	Connection box	Surface load (W/cm <sup>2</sup> )	Surface load (W/in <sup>2</sup> )	Accessory
9NNL128G23400BJ0	9NNL128423400BJ0	400	No	1.2	7.7	
9NNL188G23600BJ0	9NNL188423600BJ0	600	No	1.8	11.6	
9NNL368G23A20BJ0	9NNL368423A20BJ0	1200	No	3.6	23.2	
9NNL188G23600BJC	9NNL188423600BJC	400	Yes	1.2	7.7	Bracket and collar tube for 125mm dia. duct (zinc plated steel)
9NNL368G23A20BJC	9NNL368423A20BJC	600	Yes	1.8	11.6	
9NNL188G23600BJC	9NNL188423600BJC	1200	Yes	3.6	23.2	Reference
						9NNCT125



# Air heating elements for incorporation

## Medium power duct heaters, with finned stainless steel heaters, 3.5W/cm<sup>2</sup>, for air speed ≥ 2m/s Type 9NF

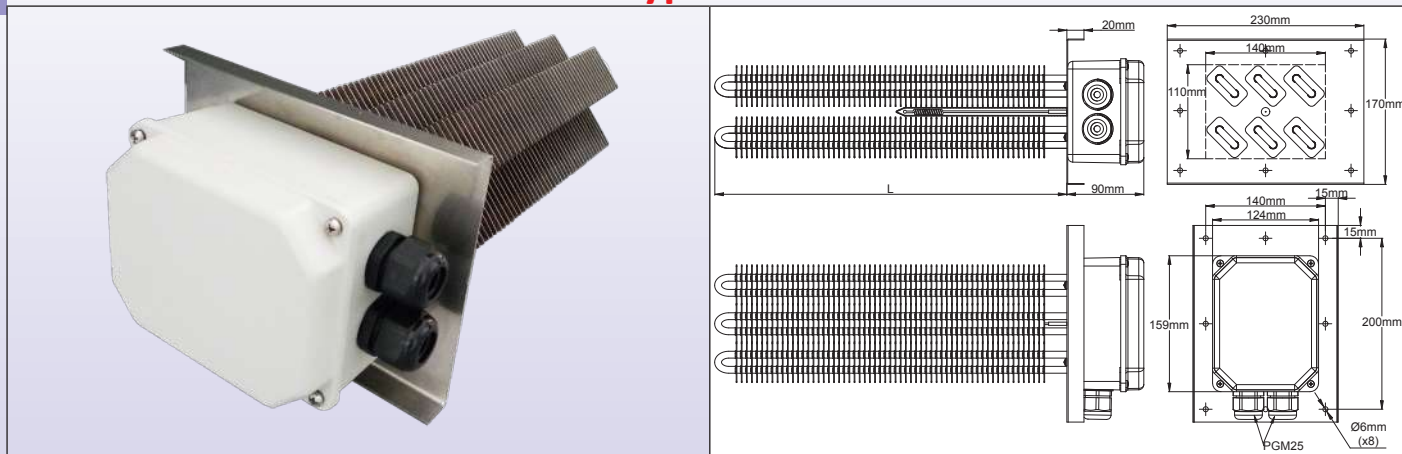

### Main applications

These medium duct heaters are mainly used in air ducts, upstream vents, for heating industrial premises, in closed hot air circuit (recirculating air) or open circuit, with a mini air speed of 2m/s. They are also used for drying, for heat treatment, dehydration, or cooking, in industrial processes. They can be used on square or rectangular ducts. They consist of finned stainless steel heating elements, mounted on a stainless steel flange. Their installation in existing pipes requests cutting a 140 × 110mm rectangular hole, and drill 8 holes for 6mm dia. screws. The electrical connections are made in an IP65 aluminum housing. These devices are equipped with a 3 pole manual reset failsafe limiter.

### Main features

**Assembly:** The finned tubes are oriented at 45° from the axis of the mounting bracket, thereby it is possible to position the duct heater along or perpendicular to the duct upon available spacing.

**Ducts minimum sizes:**

170mm heating element references: 200 × 170mm

320mm heating element references: 350 × 170mm

420mm heating element references: 450 × 170mm

**Duct opening:** 140 × 110mm rectangular hole, plus 8 holes for dia.6mm screws (or equivalent size).

**High limit thermostat:** 3 poles, failsafe, manual reset, capillary thermostat, calibrated at 120°C (other values on request). Bulb mounted inside a waterproof pocket.

**Connection box:** In gray epoxy paint aluminum housing, IP65, 160 × 124 × 92mm, fitted with two M25, PA66 cable glands.

**Minimum air velocity:** ≥ 2m/s

**Mounting bracket:** 304 stainless steel, 150 × 235mm, 1.2 mm thick, with 8 holes for M6 screws (undrilled version on request). IP65 sealing between the heating elements, connection box and bracket

**Heating elements:** 3 or 6, non-removable, finned heaters, surface load 3.5W/cm<sup>2</sup>, 304L stainless steel, with internal connection on M4 screw terminals. The power of each element is 250 watts in 170mm, 500W in 320mm and 700W in 420mm (Other features, see P4 of section 4)

**Voltage:** 230V, 50/60Hz (110-120V on request). Wiring is possible in 230V single phase, or in 400V three-phase with neutral.

**Power, surface load, air flow:**

See section 2 of this catalog tables providing surface temperatures and air temperature vs load with and without fans. However, it is up to the integrator to perform the appropriate checks of flow and temperatures reached in the application, and insure that they comply with the local regulations and safety standards.

### Main references

3 finned heating elements			6 finned heating elements		
References	Total power (W)	Length L	References	Total power (W)	Length L
9NFL170C230753NC	750	170	9NFL170C231506NC	1500	170
9NFL320C231503NC	1500	320	9NFL320C233006NC	3000	320
9NFL420C232103NC	2100	420	9NFL420C234206NC	4200	420



# Air heating elements for incorporation

## Type with tubular sheathed heating element, thermostat and high limit. Type 9SQ

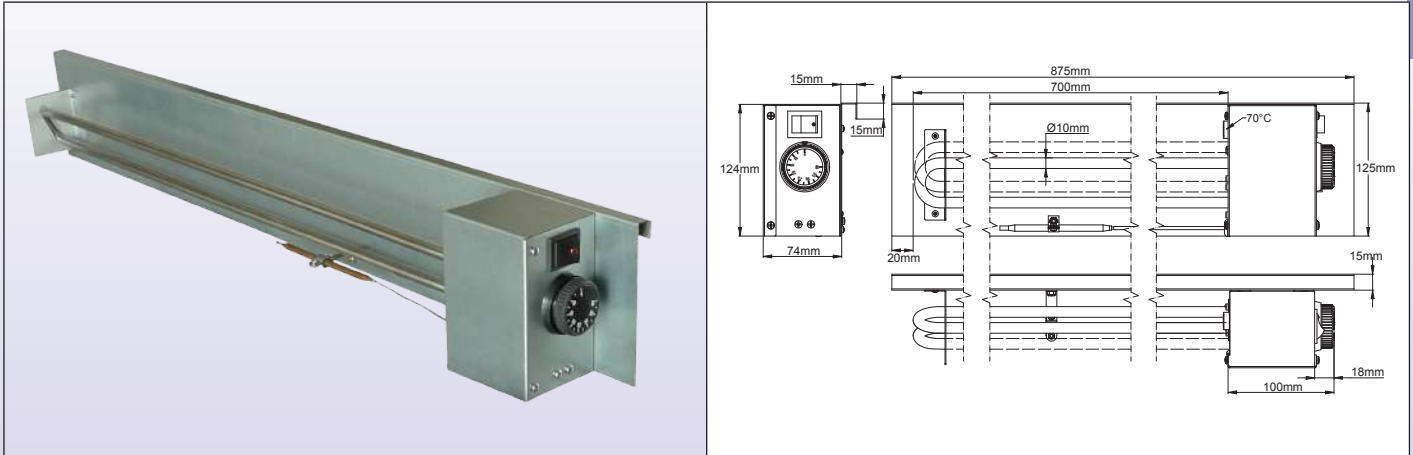

### Main applications

These heavy duty sub-assemblies are designed to allow remodeling operations in existing buildings and apartments, replacing old generation of electric heating convectors while preserving the existing locations and frames. Wall mounting by a U-rail at the rear allows easy positioning. The use of a sheathed stainless steel heating element gives an outstanding life span.

They are equipped with an adjustable thermostat, allowing local control of temperature. Their control circuit can also be controlled by a centralized control. A safety thermostat protects against the air flow outlet covering.

They exist in a version for natural convection heating and a fan assisted convection heating.

### Main features

**Dimensions:** 875 × 124 × 74mm

**Frame material:** Electro-galvanized steel

**Heating elements:** One or two sheathed elements, 10mm diameter, stainless steel 304L, length 700mm (Optional: 321 stainless steel).

**On-Off switch:** 2 poles rocker switch, illuminated

**High limit thermostat:** Disc, manual reset, open at 70°C, used to protect against obstruction of air inlet or outlets.

**Temperature control thermostat:** Bulb and capillary, temperature range 4-40°C

**Electrical connection:** Ceramic terminal block

**Surface load:**

For safe use, we recommend a maximum surface load of 1.2 W/cm<sup>2</sup> (7.8 W/in<sup>2</sup>) for applications in natural convection (surface temperature resistance ~ 300°C), and 2.4 W/cm<sup>2</sup> (15.6W/in<sup>2</sup>) for applications in forced convection (surface temperature resistance ~ 250°C for an air velocity ~ 2.5m/s).

See section 2 of this catalog tables providing surface temperatures and air temperature vs load with and without fans.

**Voltage:** 230V. Other values on request

**Tolerances on power:** +5/-10%

**Warning:** Heating element surface can reach high temperature and may cause burns or ignition of flammable materials. The integrator must ensure that in its application, these heaters cannot be touched by the final user, and cannot come into contact with combustible materials. For this purpose he must follow the installation specification requested by local and applicable standards.

**Options:**

This product can be produced on demand with different lengths. (MOQ apply).

### Main references

One heating element				Two heating elements			
References	Total power (W)	W/cm <sup>2</sup>	W/in <sup>2</sup>	References	Total power (W)	W/cm <sup>2</sup>	W/in <sup>2</sup>
9SQL12GA123050EC	500	1.2	7.8	9SQL12GA223100EC	1000	1.2	7.8
9SQL24GA123100EC	1000	2.4	15.6	9SQL24GA223200EC	2000	2.4	15.6

Because of permanent improvement of our products, drawings, descriptions, features used on these data sheets are for guidance only and can be modified without prior advice



# Air heating elements for incorporation

## Type with finned sheathed heating element, thermostat and high limit. Type 9SY

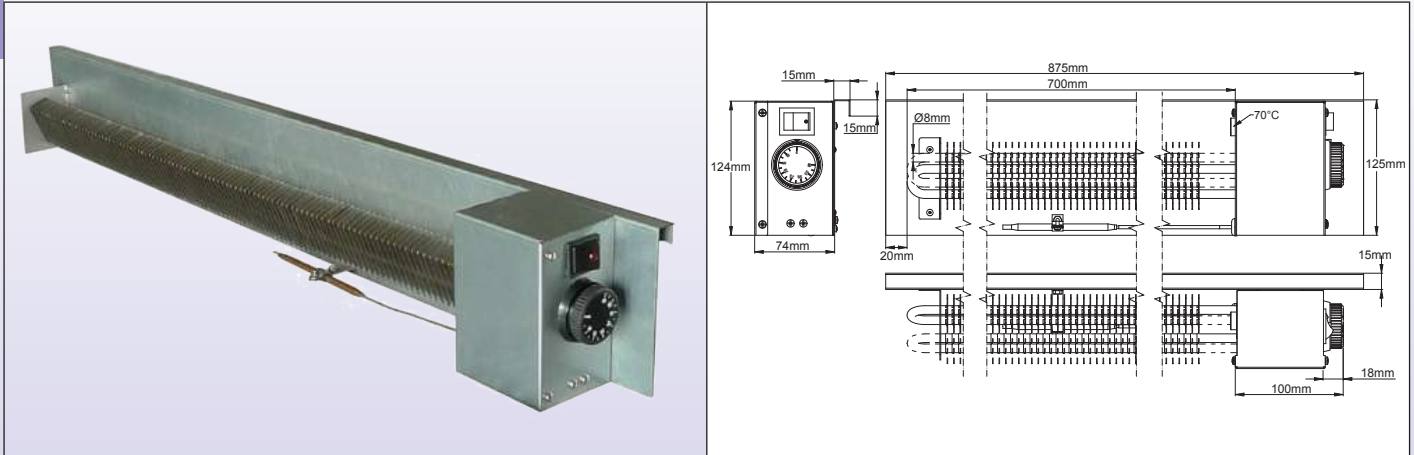

### Main applications

These heavy duty sub-assemblies are designed to allow remodeling operations in existing buildings and apartments, replacing old generation of electric heating convectors while preserving the existing locations and frames. Wall mounting by a U-rail at the rear allows easy positioning. The use of a sheathed stainless steel heating element gives an outstanding life span. They are equipped with an adjustable thermostat, allowing local control of temperature. Their control circuit can also be controlled by a centralized control. A safety thermostat protects against the air flow outlet covering. These models with fins allow a bigger power than the tubular sheathed models, and their surface temperature is lower.

### Main features

**Dimensions:** 875 × 124 × 74mm

**Frame material:** Electro-galvanized steel

**Heating elements:** One or two finned elements, stainless steel 304L, length 700mm.

**On-Off switch:** 2 poles rocker switch, illuminated

**High limit thermostat:** Disc, manual reset, open at 70°C, used to protect against obstruction of air inlet or outlets.

**Temperature control thermostat:** Bulb and capillary, temperature range 4-40°C

**Electrical connection:** Ceramic terminal block

**Surface load:**

For safe use in this application, we recommend a maximum surface load of 2.4 W/cm<sup>2</sup> (15.5 W/in<sup>2</sup>) for applications in natural convection (heating element surface temperature ~ 300°C), and 3.6 W/cm<sup>2</sup> (23.2W/in<sup>2</sup>) for applications in fan heating (heating element surface temperature ~ 300°C for an air velocity ~ 2.5m/s).

See, in last section of this catalog, surface temperatures and air temperature vs surface load, with and without fan.

**Voltage:** 230V. Other values on request

**Tolerances on power:** +5/-10%

**Warning:** Heating element surface can reach high temperature and may cause burns or ignition of flammable materials. The integrator must ensure that in its application, these heaters cannot be touched by the final user, and cannot come into contact with combustible materials. For this purpose he must follow the installation specification requested by local and applicable standards.

**Options:**

This product can be produced on demand with different lengths. (MOQ apply).

### Main references

One heating element				Two heating elements			
References	Total power (W)	W/cm <sup>2</sup>	W/in <sup>2</sup>	References	Total power (W)	W/cm <sup>2</sup>	W/in <sup>2</sup>
9SYL24GA123085EC	850	2.4	15.5	9SYL12GA223170EC	1700	2.4	15.5
9SYL36GA123125EC	1250	3.6	23.2	9SYL24GA223250EC	2500	3.6	23.2

Because of permanent improvement of our products, drawings, descriptions, features used on these data sheets are for guidance only and can be modified without prior advice



# Section 5

## Commercial and industrial convection radiators



Because of permanent improvement of our products, drawings, descriptions, features used on these data sheets are for guidance only and can be modified without prior advice





# Commercial and industrial convection radiators

## Cabinet fan heaters, range from 50 to 400W

### Type 9PF

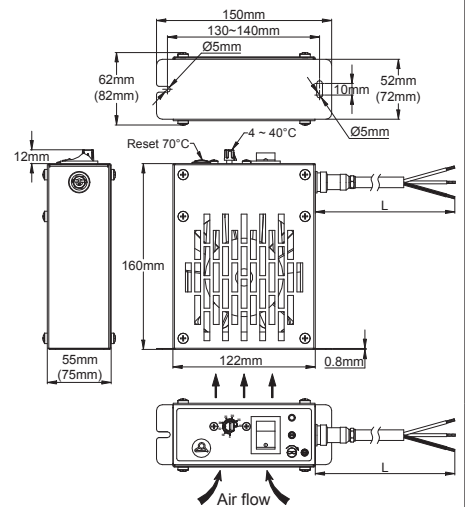

**Model 9PF3:** Self-controlled, equipped with an adjustable control thermostat which is mounted directly in the air flow, with a dial printed in °C and °F, and a fixed setting manual reset temperature limiter. In this model it is possible to select two modes of operation: Continuous ventilation mode, wherein the fan operates continuously and the thermostat switches on and off the heater depending on the temperature setting, and an automatic mode, wherein the ventilation and heating are simultaneously controlled by the thermostat.

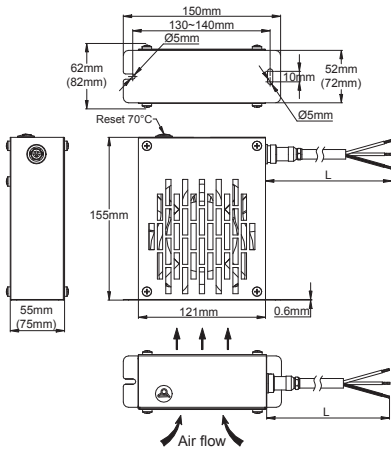

**Model 9PF1:** For remote control by thermostat or humidistat, it has only a fixed setting manual reset temperature limiter.

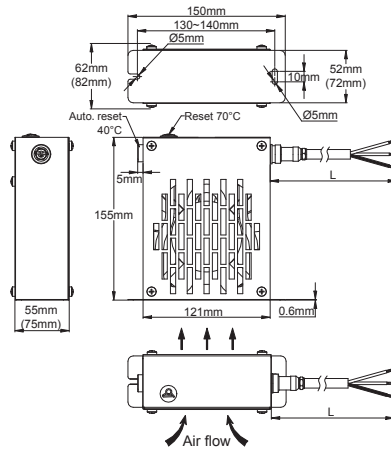

**Model 9PF2:** Self-controlled, equipped with a fixed setting control thermostat, and a fixed setting manual reset temperature limiter.

### Typical Applications:

Heavy duty fan heating in Traffic Signal Control Boxes, Automatic Teller Machines, Outdoor Electrical Power Enclosures, Control Panels, Control Valve Housings, Switch Gear, Clothing Lockers and Railway station lockers.

**Operation:** Temperature differences in cabinets, mostly in outdoor applications, often result in humidity and condensation which may cause function failures and corrosion. The use of the appropriate heating unit inside the cabinet will eliminate these problems.

Simply keep the cabinet temperature above the outer temperature (thermostat controlled models), or a humidity level below 50% (Humidistats controlled models). It also happens that the very low external temperature dips below the minimally acceptable ranges for electronics or other components. In this case the heaters are used to bring the internal temperature of the cabinet above the limit. The fan distribute the internal warm air equally throughout the control cabinet

Compared to PTC heaters, sheathed tubular heaters deliver unsurpassed strength, a power invariable in time, they do not age and do not drift, and do not produce huge peak starting current.

The metal casing provides increased mechanical protection and the best heat resistance.

### Main features

**Heating Element:** 8mm diameter, 304L sheathed stainless steel heater. Other features of these elements (Humidity resistance, insulation etc...) see P3 of section 4.

**Heater surface load:** 0.5w/cm<sup>2</sup> (2.2W/in<sup>2</sup>) or 1w/cm<sup>2</sup> (6.5W/in<sup>2</sup>) to avoid overheating.

**Case Material:** Electro-galvanized steel or 304 stainless steel according to models.

**Manual reset temperature safety cut-out:** Set at 70°C (158°F) to protect against over-heating in case of fan failure, or obstructed air flow inlet

**Setting range:** 4°C to 40°C (40 to 105°F) for adjustable models. 40°C(105°F) for fixed setting models

**Fan:** 120 × 120mm, air flow: 100m<sup>3</sup>/h. L10 life expectancy: 50,000 h (>5 years) at 25°C. L10 refers to the time at which statistically, 90% of the fan will still be operative. Life expectancy is reduced by about 50% when ambient temperature rises to 50-70°C.

**Control lamp:** Illuminated when heating is on (on model 9PF3)

Because of permanent improvement of our products, drawings, descriptions, features used on these data sheets are for guidance only and can be modified without prior advice

# Commercial and industrial convection radiators



**Operating voltage:** 220-240V AC, 50/60Hz, (100-120V AC on request).

**Operating temperature:** -45 to +70°C. Max 90% RH.

**Ingress protection:** IP 20

**Electrical connection:** By screw locking connector (cord with connector, 2 meters, H05VVH 3 × 0.75mm<sup>2</sup> supplied)

**Mounting:** Two screws, 130 to 140mm distance. We recommend installing heaters in the lower part of the cabinets, which is usually the coldest area, with ventilation blowing up, to produce optimal air circulation.

**Option:** Mounting clips for 35mm DIN rail. (EN60715).

**Accessories:**

- See P5-P6 of section 8, Din rail mounting remote thermostats and humidistat used in cabinet heaters.

- See section 2 of this catalog tables providing heaters power selection vs temperature and cabinet sizes.

(Add additional 50% to the determined power if the cabinet must be located in windy conditions)

## Main references

Type 1 (remote control)	Type 2 (built in fixed setting control)	Type 3 (built in adjustable thermostat)	Enclosure material	Thickness	Power (W)*
9PF1058LG23005EC	9PF2058LG23005EC	9PF3058LG23005EC	Zinc electro-plated steel	55mm	50W
9PF1108LG23010EC	9PF2108LG23010EC	9PF3108LG23010EC	Zinc electro-plated steel	55mm	100W
9PF1058LH23020EC	9PF2058LH23020EC	9PF3058LH23020EC	Zinc electro-plated steel	75mm	200W
9PF1108LH23040EC	9PF2108LH23040EC	9PF3108LH23040EC	Zinc electro-plated steel	75mm	400W
9PF1058L423005EC	9PF2058L423005EC	9PF3058L423005EC	304 stainless steel	55mm	50W
9PF1108L423010EC	9PF2108L423010EC	9PF3108L423010EC	304 stainless steel	55mm	100W
9PF1058L523020EC	9PF2058L523020EC	9PF3058L523020EC	304 stainless steel	75mm	200W
9PF1108L523040EC	9PF2108L523040EC	9PF3108L523040EC	304 stainless steel	75mm	400W

\* For higher power models, see page 7 of section 5

Because of permanent improvement of our products, drawings, descriptions, features used on these data sheets are for guidance only and can be modified without prior advice





# Commercial and industrial convection radiators

## 110mm compact range, IP65, without fan Type 9CG1

Because of permanent improvement of our products, drawings, descriptions, features used on these data sheets are for guidance only and can be modified without prior advice

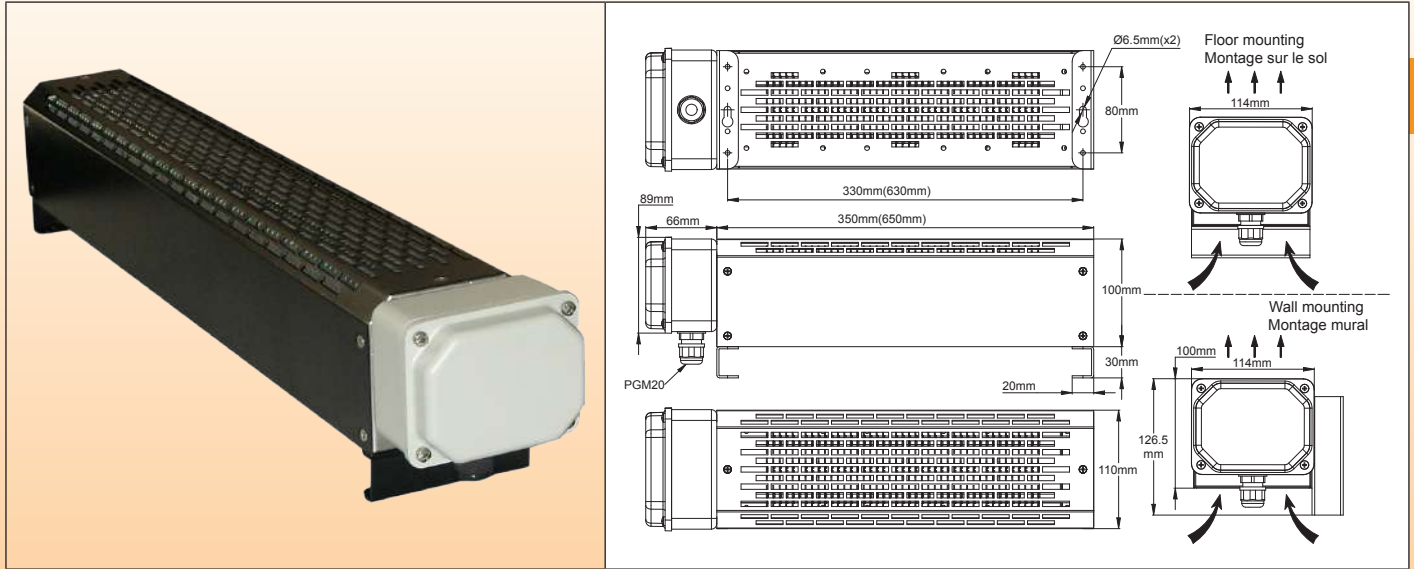

### Main applications

These heavy duty and very small sub-assemblies, are designed for assemblers, to be used as protected heating elements in professional applications, where the temperature control is added by the assembler. According to the surface power chosen, they can be used in natural convection or fan heating. They are waterproof and can be used outdoors. They exist with painted steel or stainless steel frame. The main applications are heating of professional workshops, heating small volumes such as bungalows, crane cabins, construction equipment, wagons or locomotive cockpits, technical rooms, ovens, containers, dryers.

### Main features

**Dimensions:** 2 body lengths: 350 or 650mm

**Heaters:** 3 finned elements in 304L stainless steel. Fins 25 × 50mm 304 stainless steel. Heating elements are TIG welded on their mounting bracket, which ensures a perfect seal.

**Frame material:** 0.8mm thick sheet, high strength (Withstands +100kg distributed load), two versions:

- Galvanized steel sheet with black epoxy paint
- 304 stainless steel sheet.

**Connection housing:** Die-cast aluminum with molded silicone gasket; IP65; gray epoxy paint; stainless steel screws. PA66, M20 cable gland output.

**Mounting:** 2 removable legs can be mounted under the frame (floor mounting) or on the side (wall mounting).

**Internal electrical connection:** 4 ways, 6mm<sup>2</sup>, ceramic terminal block

**Voltage:** 3 heating elements, 230V, which allows a single-phase connection (heaters wired in parallel) or 3 phases connections (heaters wired in star). Alternative voltages available on request.

**Power:** 1500 to 4500W depending on model

**Temperature range:** -50 to +150°C

**Surface load:**

We recommend a maximum surface load of 3W/cm<sup>2</sup> (20W/in<sup>2</sup>) for applications in natural convection, and 4.5 W/cm<sup>2</sup> (30W/in<sup>2</sup>) for applications in fan heating (air speed > 2m/s).

**These devices do not have a fan. It should, if necessary in the application, be installed by the assembler.**

**See section 2 of this catalog surface temperatures and air temperature in convection heating and fan heating.**

**Net weight:** 3.3kg (350mm); 5.2kg (650mm)

**Option:** Manual reset safety limit, disc or capillary type. (The selection of the set point temperature depends on the application and must be specified by the assembler).

### References with 230V power supply

Black painted steel frame					304 stainless steel frame				
References	Power (W)	L	W/cm <sup>2</sup>	W/in <sup>2</sup>	References	Power (W)	L	W/cm <sup>2</sup>	W/in <sup>2</sup>
9CG13N23023150EB	1500	350	3	20	9CG13N23023150E4	1500	350	3	20
9CG13N24523225EB	2250	350	4.5*	30	9CG13N24523225E4	2250	350	4.5*	30
9CG16N23023300EB	3000	650	3	20	9CG16N23023300E4	3000	600	3	20
9CG16N24523450EB	4500	650	4.5*	30	9CG16N24523450E4	4000	600	4.5*	30

\*Air velocity ≥2m/s is mandatory

# Commercial and industrial convection radiators



## 130mm range, IP65, without fan Type 9CG3

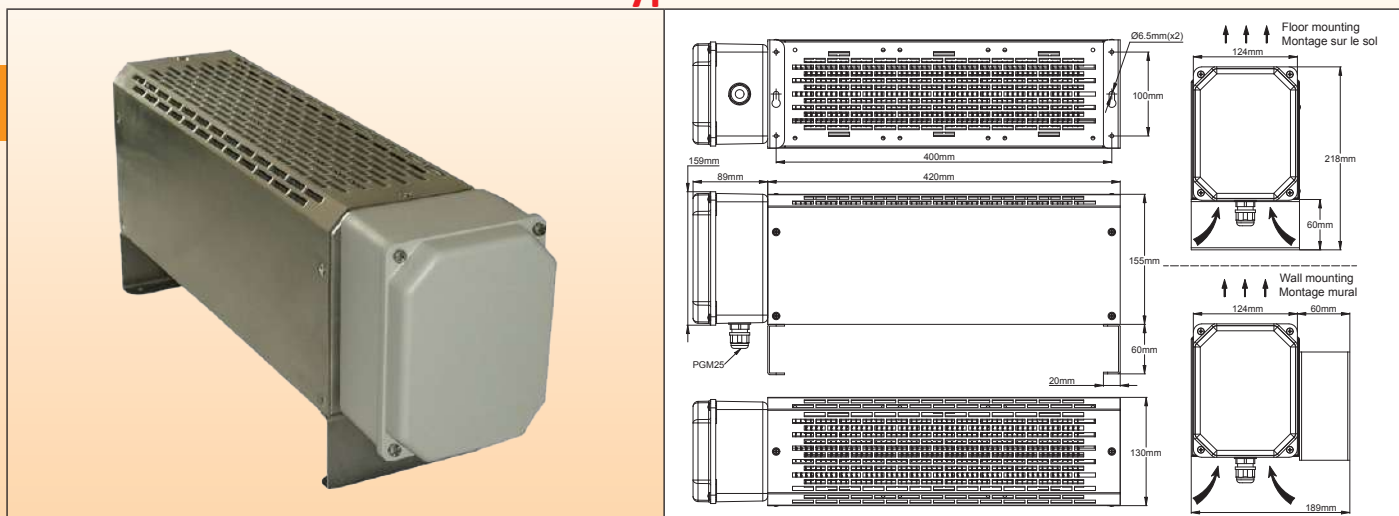

### Main applications

These heavy duty sub-assemblies, are designed for assemblers, to be used as protected heating elements in professional applications, where the temperature control is added by the assembler.

According to the surface power chosen, they can be used in natural convection or fan heating.

They are waterproof and can be used outdoors. They exist with painted steel or stainless steel frame.

The main applications are heating of professional workshops, heating small volumes such as bungalows, crane cabins, construction equipment, wagons or locomotive cockpits, technical rooms, ovens, containers, dryers.

### Main features

**Dimensions:** 420 × 130 × 155mm body length

**Heaters:** 3 or 6 finned elements in 304L stainless steel. Fins 25 × 50mm 304 stainless steel. Heating elements are TIG welded on their mounting bracket, which ensures a perfect seal.

**Frame material:** 0.8mm thick sheet, high strength (Withstands +100kg distributed load), two versions:

- Galvanized steel sheet with black epoxy paint
- 304 stainless steel sheet.

**Connection housing:** 159 × 124 × 89mm, die-cast aluminum with molded silicone gasket; IP65; gray epoxy paint; stainless steel screws. PA66, M25 cable gland output.

**Mounting:** 2 removable legs can be mounted under the frame (floor mounting) or on the side (wall mounting).

**Internal electrical connection:** 10mm<sup>2</sup>, 4 ways, ceramic terminal block

**Voltage:** 3 heating elements, 230V, which allows a single-phase connection (heaters wired in parallel) or 3 phases connections (heaters wired in star). Alternative voltages available on request.

**Power:** 1500 to 4500W depending on model

**Temperature range:** -50 to +150°C

**Surface load:**

We recommend a maximum surface load of 3W/cm<sup>2</sup> (20W/in<sup>2</sup>) for applications in natural convection, and 4.5 W/cm<sup>2</sup> (30W/in<sup>2</sup>) for applications in fan heating (air speed > 2m/s).

**These devices do not have a fan. It should, if necessary in the application, be installed by the assembler.**

**See section 2 of this catalog surface temperatures and air temperature in convection heating and fan heating.**

**Net weight:** 6.4kg

**Option:** Manual reset safety limit, disc or capillary type. (The selection of the set point temperature depends on the application and must be specified by the assembler).

### References with 230V power supply

Black painted steel frame					304 stainless steel frame				
References	Power (W)	Heating element quantity	W/cm <sup>2</sup>	W/in <sup>2</sup>	References	Power (W)	Heating element quantity	W/cm <sup>2</sup>	W/in <sup>2</sup>
9CG34G33023200EB	2000	3	3	20	9CG34G33023200E4	2000	3	3	20
9CG34G34523230EB	2300	3	4.5*	30	9CG34G34523230E4	2300	3	4.5*	30
9CG34G63023400EB	4000	6	3	20	9CG34G63023400E4	4000	6	3	20
9CG34G64523460EB	4600	6	4.5*	30	9CG34G64523460E4	4600	6	4.5*	30

\* Air velocity ≥2m/s is mandatory

# Commercial and industrial convection radiators



## Upward blowing models Type 9CH

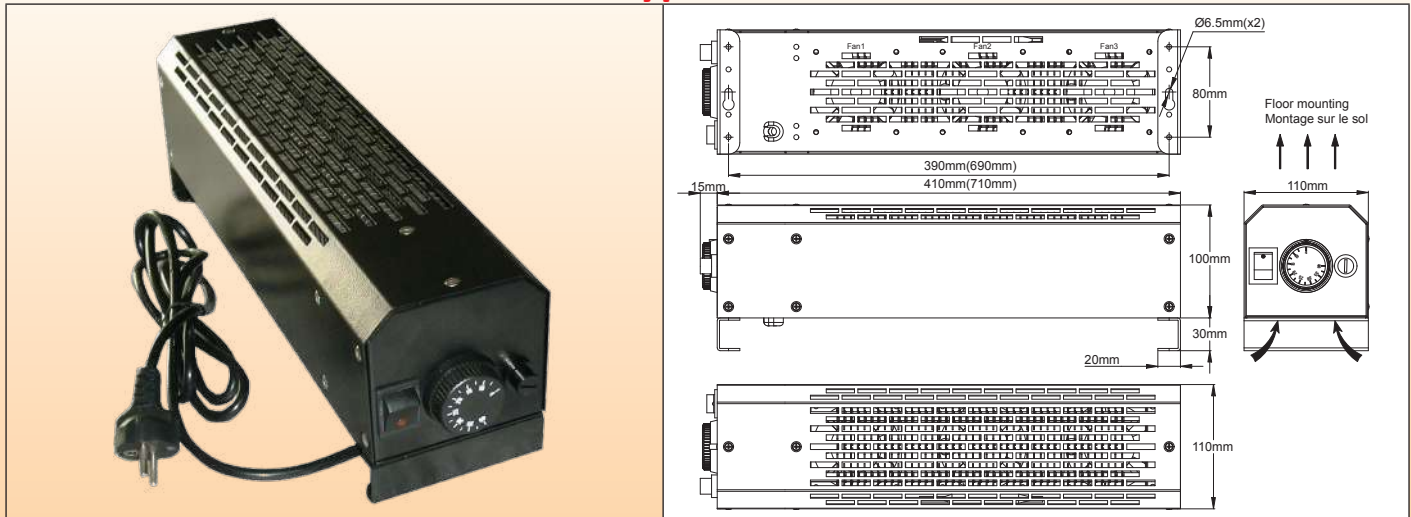

### Main applications

These heavy duty fan heaters, are characterized by their very small size, and are designed for professional, commercial or industrial applications. They are equipped with 3 ultra-thin fans, with a 2 poles, illuminated on-off switch, an adjustable control thermostat and a safety thermostat. Although their heating elements are shielded and sealed, their fans and control box are not waterproof, and they should not be used outdoors. Their insulation class 1 does not allow to use them in bathroom and in all places requiring Class II insulation. They are not designed for use in hazardous environments. They exist with painted steel or stainless steel frame. The main applications are heating of professional workshops, heating small volumes such as bungalows, crane cabins, construction equipment, wagons or locomotive cockpits, technical rooms, ovens, containers, dryers. They can also be used as electrical heaters for large size electrical cabinets.

### Main features

- Dimensions:** 2 body lengths: 410 or 710mm
- Ingress protection:** IP41
- Heaters:** 3 finned elements in 304L stainless steel. Fins 25 × 50mm 304 stainless steel. Surface load 3W/cm<sup>2</sup>
- Frame material:** 0.8mm thick sheet, high strength (Withstands +100kg distributed load), two versions:
  - Galvanized steel sheet with black epoxy paint
  - 304 stainless steel sheet.
- Fans:** 3 fans of 80 × 80mm, flow 3 × 30m<sup>3</sup>/h. L10 life expectancy: 50,000 h (>5 years) at 25°C. L10 refers to the time at which statistically, 90% of the fan will still be operative. Life expectancy is reduced by about 50% when ambient temperature rises to 50-70°C.
- Controls:** Adjustable bulb and capillary control thermostat, range 4 to 40°C, and fail safe high limit manual reset thermostat for protection against air outlet obstruction or fan failure.
- Electrical connection:** By grounded euro plug, 2 meters, 3 × 1.5mm<sup>2</sup>
- Mounting:** 2 removable legs can be mounted under the frame (floor mounting) or on the side (wall mounting).
- Voltage:** 230V, 50/60Hz. Other voltages available on request.
- Power:** 1500W (410mm) and 3000W (710mm)
- Ambient temperature:** -20 to +60°C
- Net weight:** 4.1kg (410mm) ; 5.9kg (710mm)
- Option:** Customization accepted

### References with 230V power supply

Black painted steel frame			304 stainless steel frame		
References	Power (W)	L	References	Power (W)	L
9CH14033023150HB	1500	410	9CH14033023150H4	1500	410
9CH17033023300HB	3000	710	9CH17033023300H4	3000	710

Because of permanent improvement of our products, drawings, descriptions, features used on these data sheets are for guidance only and can be modified without prior advice

## Downward blowing models Type 9CL

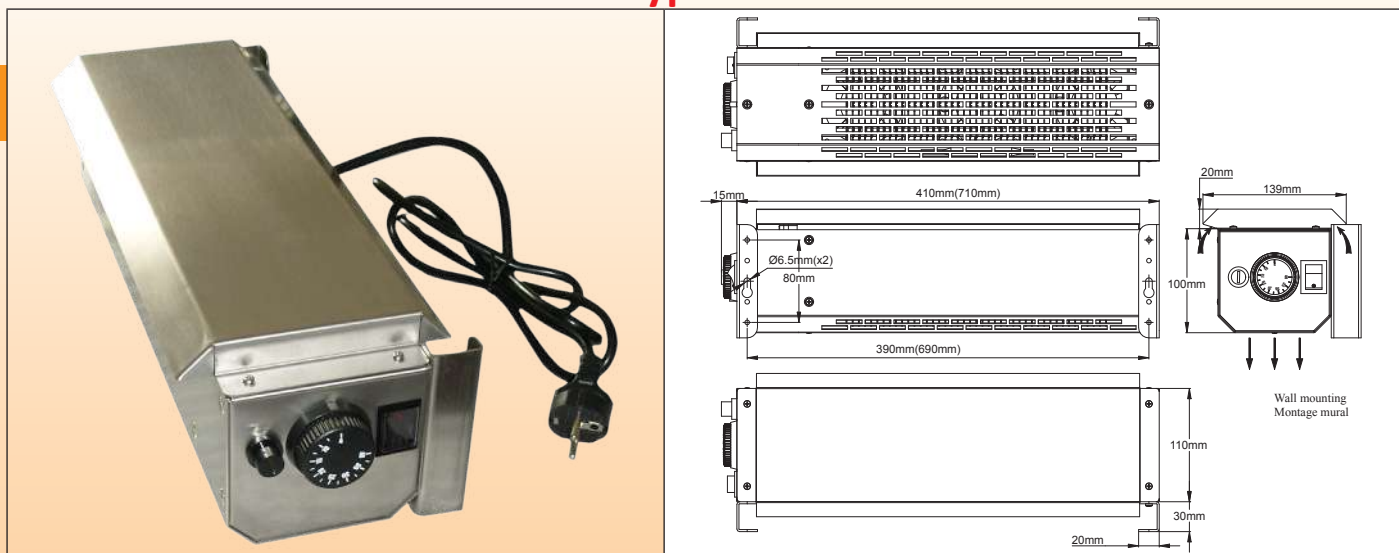

### Main applications

These heavy duty fan heaters, downward blowing, are characterized by their very small size, and are designed for professional, commercial or industrial applications.

They must be mounted on a vertical wall, at more than 40cm from the floor or any board.

Top side air inlets are equipped with a baffle protecting the fans against liquid drops or particle inlet.

They are equipped with 3 ultra-thin fans, with a 2 poles, illuminated on-off switch, an adjustable control thermostat and a safety thermostat.

Although their heating elements are shielded and sealed, their control box is not waterproof, and they should not be used outdoors. Their insulation class 1 does not allow to use them in bathroom and in all places requiring Class II insulation. They are not designed for use in hazardous environments.

They exist with painted steel or stainless steel frame.

The main applications are heating of professional workshops, heating small volumes such as bungalows, crane cabins, construction equipment, wagons or locomotive cockpits, technical rooms, ovens, containers, dryers.

### Main features

**Dimensions:** 2 body lengths: 410 or 710mm

**Ingress protection:** IP44

**Heaters:** 3 finned elements in 304L stainless steel. Fins 25 × 50mm 304 stainless steel. Surface load 3W/cm<sup>2</sup>

**Frame material:** 0.8mm thick sheet, high strength (Withstands +100kg distributed load), two versions:

- Galvanized steel sheet with black epoxy paint
- 304 stainless steel sheet.

**Fans:** 3 fans of 80 × 80mm, flow 3 × 30m<sup>3</sup>/h. L10 life expectancy: 50,000 h (>5 years) at 25°C. L10 refers to the time at which statistically, 90% of the fan will still be operative. Life expectancy is reduced by about 50% when ambient temperature rises to 50-70°C.

**Controls:** Adjustable bulb and capillary control thermostat, range 4 to 40°C, and fail safe high limit manual reset thermostat for protection against air outlet obstruction or fan failure. (Both controls protected against water ingress)

**Main switch:** 2 poles, on off, illuminated, with water ingress protection boot

**Electrical connection:** By grounded euro plug, 2 meters, 3 × 1.5mm<sup>2</sup>

**Mounting:** 2 wall mounting legs

**Voltage:** 230V, 50/60Hz. Other voltages available on request.

**Power:** 1500W (410mm) and 3000W (710mm)

**Ambient temperature:** -20 to +60°C

**Net weight:** 4.6kg (410mm) ; 6.8kg (710mm)

**Option:** Customization accepted.

### References with 230V power supply

Black painted steel frame			304 stainless steel frame		
References	Power (W)	L	References	Power (W)	L
9CL14033023150HB	1500	410	9CL14033023150H4	1500	410
9CL17033023300HB	3000	710	9CL17033023300H4	3000	710

\* Air velocity ≥2m/s is mandatory



## Upward blowing models, thermostat control Type 9CJ

Because of permanent improvement of our products, drawings, descriptions, features used on these data sheets are for guidance only and can be modified without prior advice

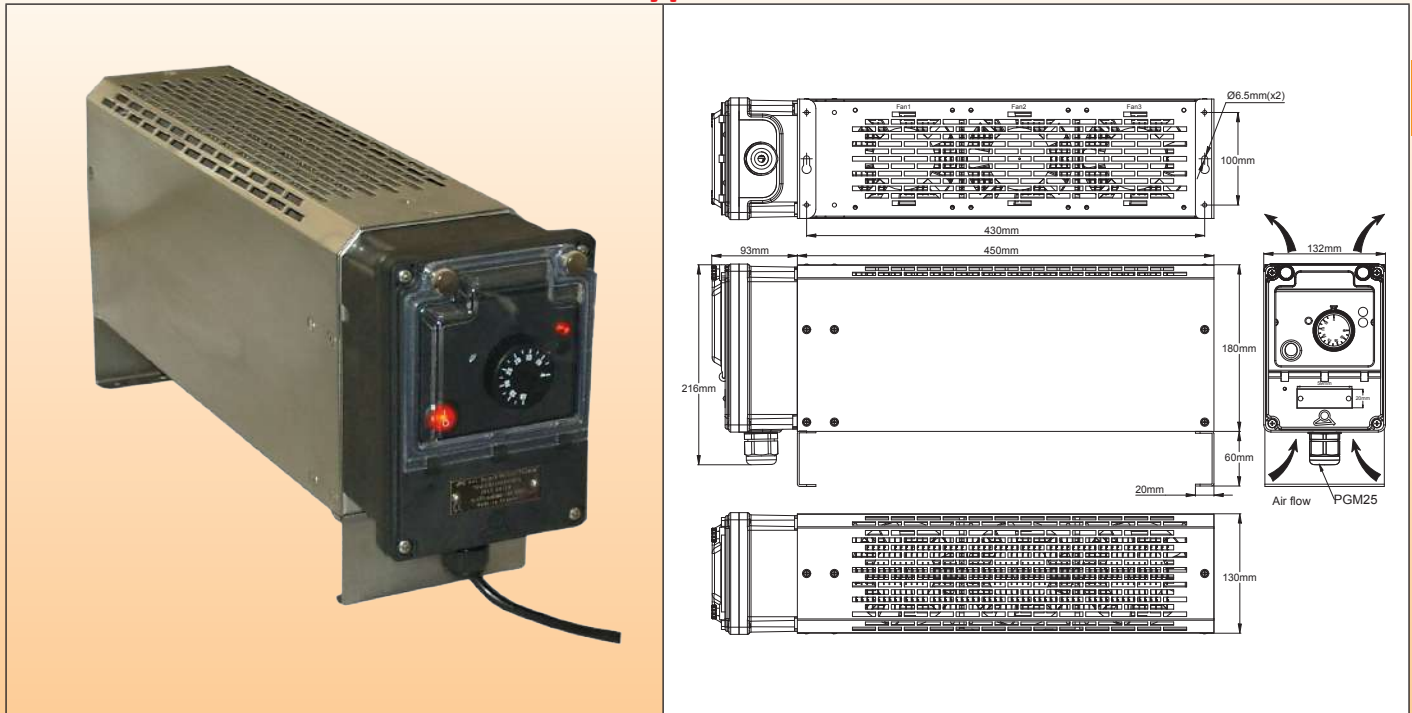

### Main applications

These heavy duty fan heaters, are designed for professional, commercial or industrial applications.

They are equipped with 3 silent high flow fans, and a waterproof control box equipped with a 2 poles, illuminated on-off switch, an adjustable control thermostat, a safety thermostat, and a tip over switch.

Although their heating elements and control boxes are waterproof, their fans are not, and they should not be used outdoors without proper protection of the hot air outlets against liquid drops and rain.

For outdoor applications, use the models without fans.

Their insulation class 1 does not allow using them in bathroom and in all places requiring Class II insulation. They are not designed for use in hazardous environments.

They exist with painted steel or stainless steel frame.

The main applications are heating of professional workshops, bungalows, crane cabins, construction equipment, wagons or locomotive cockpits, technical rooms, ovens, containers, dryers.

### Main features

**Dimensions:** 450 × 130 × 150mm body (control box and legs not included)

**Ingress protection:** IP40 (fan heater models), or IP65 (models without fans)

**Heaters:** 3 finned elements in 304L stainless steel. Fins 25 × 50mm 304 stainless steel. Surface load 3W/cm<sup>2</sup> for fan models and 2W/cm<sup>2</sup> for no fan models.

**Frame material:** 0.8mm thick sheet, high strength (Withstands +100kg distributed load), two versions:

- Galvanized steel sheet with black epoxy paint
- 304 stainless steel sheet.

**Fans (only for models with fans):** 3 fans of 120 × 120mm, flow 3 × 30m<sup>3</sup>/h. L10 life expectancy: 50,000 h (>5 years) at 25°C. L10 refers to the time at which statistically, 90% of the fan will still be operative. Life expectancy is reduced by about 50% when ambient temperature rises to 50-70°C.

#### Controls:

Located inside a PA66, IP65, IK10 protection box, with sealable window, providing access to:

- Adjustable bulb and capillary control thermostat, range 4 to 40°C,
- Fail safe high limit manual reset thermostat for protection against air outlet obstruction or fans failure
- Tip-over switch to protect against heater fail over

**Electrical connection:** By grounded euro plug, 2 meters, 3 × 1.5mm<sup>2</sup> (no cable supplied in the 3 phases version)

**Mounting:** 2 removable legs can be mounted under the frame (floor mounting) or on the side (wall mounting).

**Voltage:** Single phase 230V, 50/60Hz or 400V three phases with neutral

#### Power:

- IP40 single phase, 230V: 2000W, 3500W; 3 phases: 4000W
- IP65 single phase, 230V: 1300W, 2600W; 3 phases: 2600W

**Ambient temperature:** -20 to +60°C

**Net weight:** 8.1 kg



# Commercial and industrial convection radiators



## Option:

- Infrared on-off remote control
- Customization accepted

References, IP40 version with fans					
Black painted steel frame			304 stainless steel frame		
References	Power (W)	Voltage (V)	References	Power (W)	Voltage (V)
9CJ34Y33023200HB	2000	230	9CJ34Y33023200H4	2000	230
9CJ34Y63023300HB	3500	230	9CJ34Y63023300H4	3500	230
9CJ34Y630433000B	4000	3 × 400	9CJ34Y6304330004	4000	3 × 400

  

References, IP65 version without fans					
Black painted steel frame			304 stainless steel frame		
References	Power (W)	Voltage (V)	References	Power (W)	Voltage (V)
9CJ3DY32023130HB	1300	230	9CJ3DY32023130H4	1300	230
9CJ3DY23023260HB	2600	230	9CJ3DY62023260H4	2600	230
9CJ3DY620432600B	2600	3 × 400	9CJ3DY6204326004	2600	3 × 400

Because of permanent improvement of our products, drawings, descriptions, features used on these data sheets are for guidance only and can be modified without prior advice



## Upward blowing models, electronic control Type 9CK

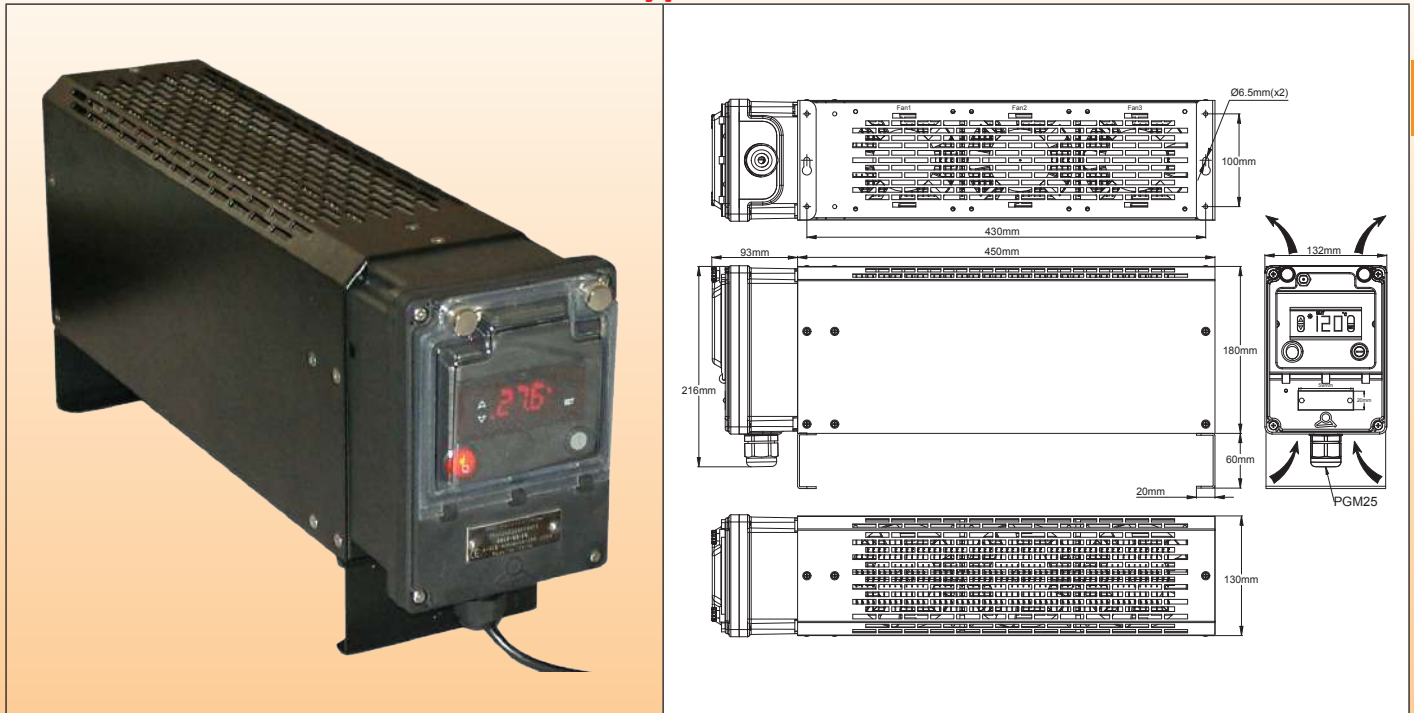

### Main applications

These heavy duty fan heaters, are designed for professional, commercial or industrial applications. They are equipped with 3 silent high flow fans, and a waterproof control box equipped with a 2 poles, illuminated on-off switch, an electronic temperature control with digital display, a safety thermostat, and a tip over switch. Although their heating elements and control boxes are waterproof, their fans are not, and they should not be used outdoors without proper protection of the hot air outlets against liquid drops and rain. For outdoor application, use the models without fans. Their insulation class 1 does not allow using them in bathroom and in all places requiring Class II insulation. They are not designed for use in hazardous environments. They exist with painted steel or stainless steel frame. The main applications are heating of professional workshops, bungalows, crane cabins, construction equipment, wagons or locomotive cockpits, technical rooms, ovens, containers, dryers.

### Main features

- Dimensions:** 450 × 130 × 150mm body (control box and legs not included)
- Ingress protection:** IP40 (fan heater version) or IP65 (version without fans)
- Heaters:** 3 finned elements in 304L stainless steel. Fins 25 × 50mm 304 stainless steel. Surface load 3W/cm<sup>2</sup> for fan models and 2W/cm<sup>2</sup> for no fan models.
- Frame material:** 0.8mm thick sheet, high strength (Withstands +100kg distributed load), two versions:
  - Galvanized steel sheet with black epoxy paint
  - 304 stainless steel sheet.
- Fans (only for version with fans):** 3 fans of 120 × 120mm, flow 3 × 30m<sup>3</sup>/h. L10 life expectancy: 50,000 h (>5 years) at 25°C. L10 refers to the time at which statistically, 90% of the fan will still be operative. Life expectancy is reduced by about 50% when ambient temperature rises to 50-70°C.
- Controls:** Located inside a PA66, IK10 protection box, with sealable window, providing access to:
  - Electronic temperature control, with differential adjustment, digital display at 1/10°, temperature range 4-40°C (can be set in °F)
  - Fail safe high limit manual reset thermostat for protection against air outlet obstruction or fan failure
  - Tip-over switch to protect against heater fail over
- Electrical connection:** By grounded euro plug, 2 meters, 3 × 1.5mm<sup>2</sup> (no cable supplied in the 3 phases version)
- Mounting:** 2 removable legs can be mounted under the frame (floor mounting) or on the side (wall mounting).
- Voltage:** Single phase 230V, 50/60Hz or 400V three phases with neutral
- Power:**
  - IP40 single phase, 230V: 2000W, 3500W; 3 phases: 4000W
  - IP65 single phase, 230V: 1300W, 2600W; 3 phases: 2600W
- Ambient temperature:** -20 to +60°C
- Net weight:** 8.4 kg

# Commercial and industrial convection radiators



## Option:

- Infrared on-off remote control
- Customization accepted

References, IP40 version with fans					
Black painted steel frame			304 stainless steel frame		
References	Power (W)	Voltage (V)	References	Power (W)	Voltage (V)
9CK34Y33023200HB	2000	230	9CK34Y33023200H4	2000	230
9CK34Y63023300HB	3500	230	9CK34Y63023300H4	3500	230
9CK34Y630433000B	4000	3 × 400	9CK34Y6304330004	4000	3 × 400

References, IP65 version without fans					
Black painted steel frame			304 stainless steel frame		
References	Power (W)	Voltage (V)	References	Power (W)	Voltage (V)
9CK3DY32023130HB	1300	230	9CK3DY32023130H4	1300	230
9CK3DY23023260HB	2600	230	9CK3DY62023260H4	2600	230
9CK3DY620432600B	2600	3 × 400	9CK3DY6204326004	2600	3 × 400

Because of permanent improvement of our products, drawings, descriptions, features used on these data sheets are for guidance only and can be modified without prior advice



# Commercial and industrial convection radiators

## Thermostat control Type 9CR

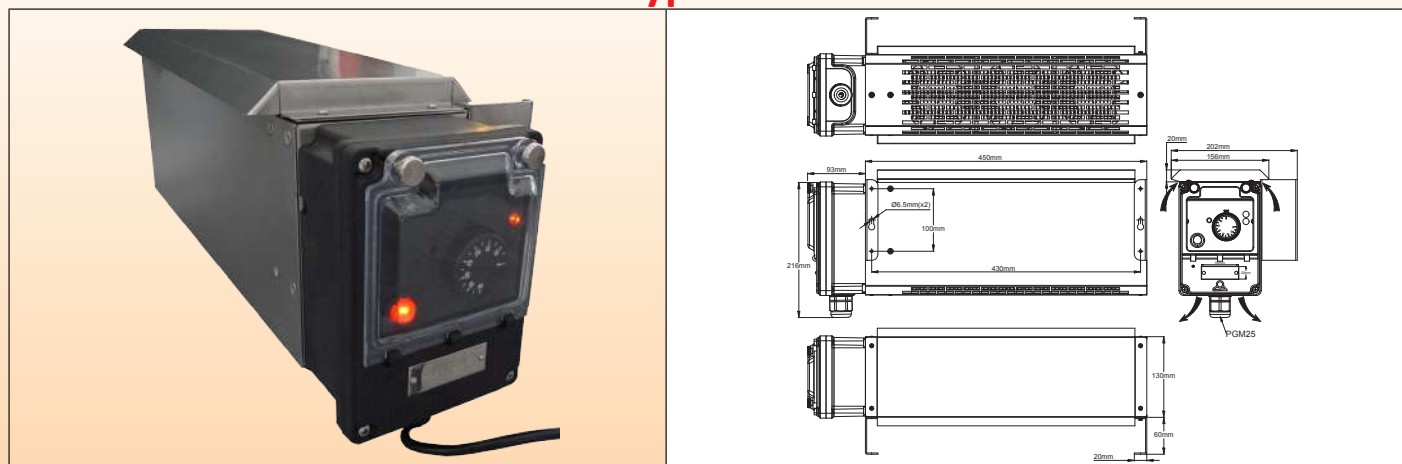

### Main applications

These heavy duty fan heaters, downward blowing, are designed for professional, commercial or industrial applications. They must be mounted on a vertical wall, at more than 40cms from the floor or any board. Top side air inlets are equipped with a baffle protecting the fans against liquid drops or particle inlet. They are equipped with 3 silent high flow fans, and a waterproof control box equipped with a 2 poles, illuminated on-off switch, an adjustable control thermostat, and a safety thermostat. Their insulation class 1 does not allow using them in bathrooms and in all places requiring Class II insulation. They are not designed for use in hazardous environments. They exist with painted steel or stainless steel frame. The main applications are heating of professional workshops, bungalows, crane cabins, construction equipment, wagons or locomotive cockpits, technical rooms, ovens, containers, dryers.

### Main features

**Dimensions:** 450 × 130 × 150mm body (control box and legs not included)

**Ingress protection:** IP44

**Heaters:** 3 finned elements in 304L stainless steel. Fins 25 × 50mm 304 stainless steel. Surface load 3W/cm<sup>2</sup>.

**Frame material:** 0.8mm thick sheet, high strength (Withstands +100kg distributed load), two versions:

- Galvanized steel sheet with black epoxy paint
- 304 stainless steel sheet.

**Fans:** 3 fans of 120 × 120mm, flow 3 × 30m<sup>3</sup>/h. L10 life expectancy: 50,000 h (>5 years) at 25°C. L10 refers to the time at which statistically, 90% of the fan will still be operative. Life expectancy is reduced by about 50% when ambient temperature rises to 50-70°C.

#### Controls:

Located inside a PA66, IP65, IK10 protection box, with sealable window, providing access to:

- Adjustable bulb and capillary control thermostat, range 4 to 40°C,
- Fail safe high limit manual reset thermostat for protection against air outlet obstruction or fan failure

**Electrical connection:** By grounded euro plug, 2 meters, 3 × 1.5mm<sup>2</sup> (no cable supplied in the 3 phases version)

**Mounting:** 2 wall mounting legs

**Voltage:** Single phase 230V, 50/60Hz or 400V three phases with neutral

**Power:** Single phase, 230V: 2000W, 3500W; 3 phases: 4000W

**Ambient temperature:** -20 to +60°C

**Net weight:** 8.8 kg

#### Options:

- Infrared remote switch
- Customization accepted

Net weight: 8.4 kg

### References

Black painted steel frame			304 stainless steel frame		
References	Power (W)	Voltage (V)	References	Power (W)	Voltage (V)
9CR34Y33023200HB	2000	230	9CR34Y33023200H4	2000	230
9CR34Y63023300HB	3500	230	9CR34Y63023300H4	3500	230
9CR34Y630433000B	4000	3 × 400	9CR34Y6304330004	4000	3 × 400

## Electronic control Type 9CS

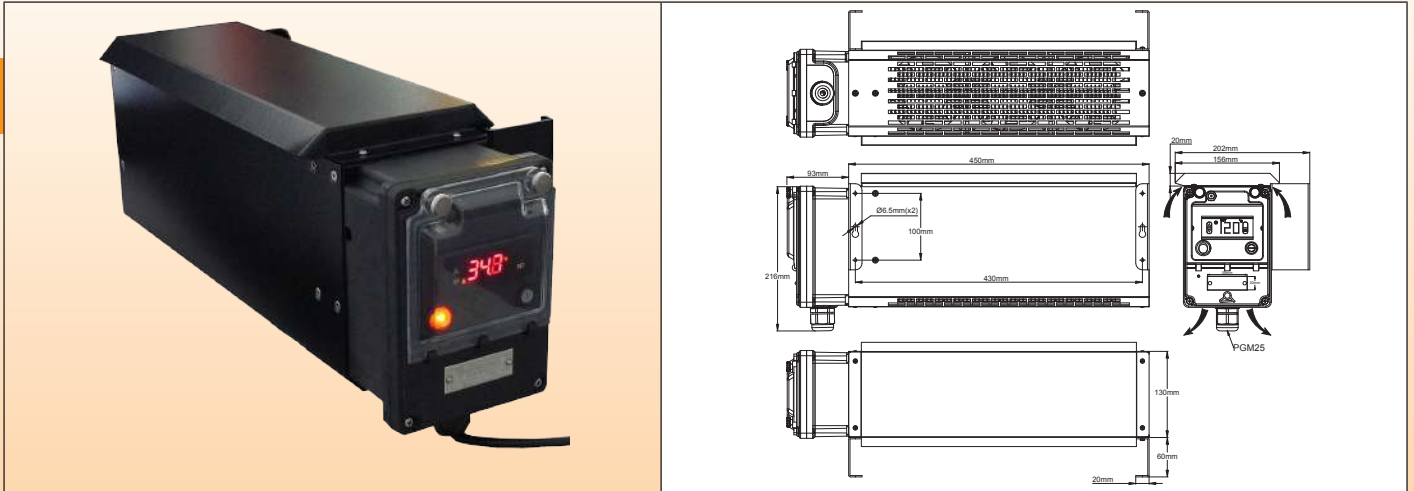

### Main applications

These heavy duty fan heaters, are designed for professional, commercial or industrial applications. They must be mounted on a vertical wall, at more than 40cms from the floor or any board. Top side air inlets are equipped with a baffle protecting the fans against liquid drops or particle inlet. They are equipped with 3 silent high flow fans, and a waterproof control box equipped with a 2 poles, illuminated on-off switch, an electronic temperature control with digital display, and a safety thermostat. Their insulation class 1 does not allow using them in bathroom and in all places requiring Class II insulation. They are not designed for use in hazardous environments. They exist with painted steel or stainless steel frame. The main applications are heating of professional workshops, bungalows, crane cabins, construction equipment, wagons or locomotive cockpits, technical rooms, ovens, containers, dryers.

### Main features

**Dimensions:** 450 × 130 × 150mm body (control box and legs not included)

**Ingress protection:** IP44

**Heaters:** 3 finned elements in 304L stainless steel. Fins 25 × 50mm 304 stainless steel. Surface load 3W/cm<sup>2</sup>

**Frame material:** 0.8mm thick sheet, high strength (Withstands +100kg distributed load), two versions:

- Galvanized steel sheet with black epoxy paint
- 304 stainless steel sheet.

**Fans (only for version with fans):** 3 fans of 120 × 120mm, flow 3 × 30m<sup>3</sup>/h. L10 life expectancy: 50,000 h (>5 years) at 25°C. L10 refers to the time at which statistically, 90% of the fan will still be operative. Life expectancy is reduced by about 50% when ambient temperature rises to 50-70°C.

**Controls:** Located inside a PA66, IP65, IK10 protection box, with sealable window, providing access to:

- Electronic temperature control, with differential adjustment, digital display at 1/10°, temperature range 4-40°C (can be set in °F)
- Fail safe high limit manual reset thermostat for protection against air outlet obstruction or fans failure
- Tip-over switch to protect against heater fail over (not available in the 3 phases version)

**Electrical connection:** By grounded euro plug, 2 meters, 3 × 1.5mm<sup>2</sup> (no cable supplied in the 3 phases version)

**Mounting:** 2 legs on the side (wall mounting).

**Voltage:** Single phase 230V, 50/60Hz or 400V three phases with neutral

**Power:** Single phase, 230V: 2000W, 3500W; 3 phases: 4000W

**Ambient temperature:** -20 to +60°C

**Net weight:** 9.1 kg

**Option:**

- Infrared remote on-off switch
- Customization accepted

### References

Black painted steel frame			304 stainless steel frame		
References	Power (W)	Voltage (V)	References	Power (W)	Voltage (V)
9CS34Y33023200HB	2000	230	9CS34Y33023200H4	2000	230
9CS34Y63023300HB	3500	230	9CS34Y63023300H4	3500	230
9CS34Y630433000B	4000	3 × 400	9CS34Y6304330004	4000	3 × 400





Because of permanent improvement of our products, drawings, descriptions, features used on these data sheets are for guidance only and can be modified without prior advice

# Section 6

## Waterproof industrial radiators



Because of permanent improvement of our products, drawings, descriptions, features used on these data sheets are for guidance only and can be modified without prior advice



# Waterproof industrial radiators

**Small industrial electric baseboard heaters, natural convection, width 110mm, IP69K (high pressure hot water) waterproof grade, IK10 shockproof grade, with 1 or 2 finned heating elements, 600W and 1200W.**

## Type 9CA

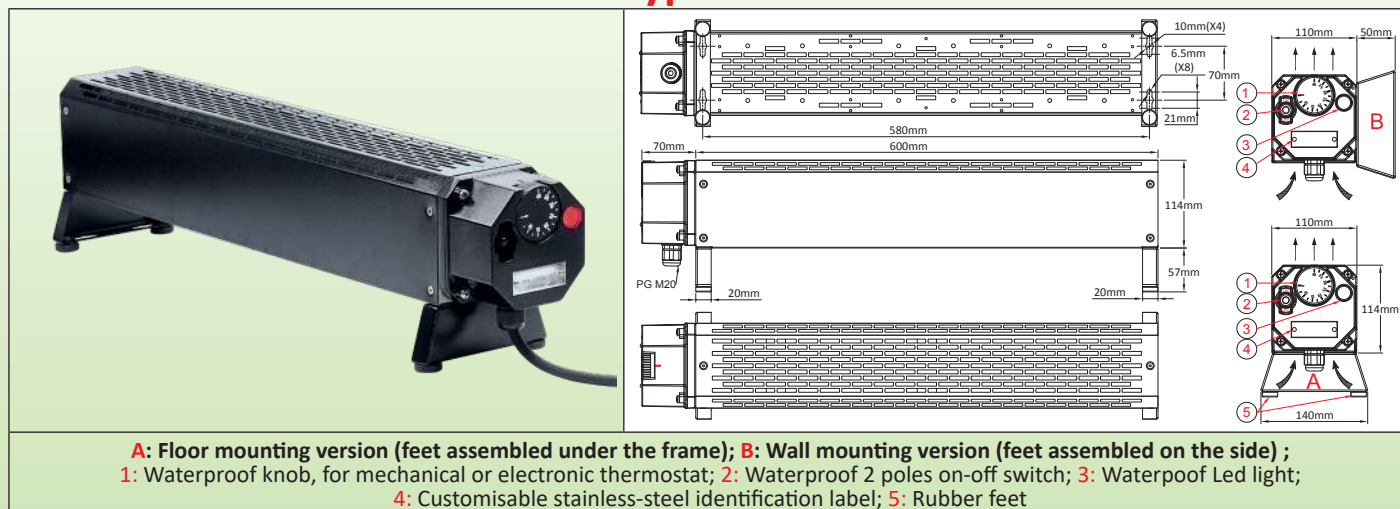

### Main applications

These heavy-duty heaters, are designed for **professional, commercial or industrial applications**. They are exceptionally **sturdy and washable with hot water karcher**.

They are equipped with a waterproof control box equipped with a multipole on-off switch, a pilot light, an adjustable control thermostat (mechanical or electronic), a safety limiter, and a tip over switch.

They are not designed for use in hazardous environments.

They exist with painted steel or stainless-steel body.

The main applications are heating of professional workshops, bungalows, cranes cabins, construction equipment, wagons or locomotives cockpit, technical rooms, ovens, containers, dryers, pharmaceutical and food laboratories, breeding premises, military equipment, and electrical cabinets.

### Main features

**Dimensions:** Heating body 600 × 110 × 110mm (legs not included). Total length 670mm.

**Protection:** Ingress: IP69K; shocks: IK10.

**Heaters:** 1 or 2 finned elements in 304L stainless steel. Fins 25 × 50mm 304 stainless steel. Surface load 2W/cm<sup>2</sup>.

**Frame material:** 0.8mm thick sheet, high strength (Withstands +100kg distributed load), two versions:

- Steel sheet with epoxy paint. Black is standard. Grey Ral 7035 available with MOQ 100p.
- 304 stainless steel sheet.

**Controls:** Located inside an epoxy painted aluminum enclosure, sealable. It includes:

- One adjustable thermostat, **mechanical or electronic**, range 4 to 40°C.
- One manual reset disc thermostat for protection against air outlet obstruction.
- One tip-over switch to protect against heater fail over.

**Electrical connection:** H05RR-F cable, length 2 meters, 3 × 1mm<sup>2</sup>.

**Mounting:** 2 removable legs can be mounted under the frame (floor mounting) or on the side (wall mounting).

**Voltage:** Single phase 230V, 50/60Hz.

**Power:** 600W (1 heating element) or 1200W (2 heating elements).

**Ambient temperature:** -20 to +60°C.

**Net weight:** 4.7 kg

#### References with mechanical thermostat, 4-40°C, differential less than 1°C

Black painted steel body			304 stainless-steel body		
References	Power (W)	Voltage (V)	References	Power (W)	Voltage (V)
9CAR7S12023060EB	600	230	9CAR7S12023060EH	600	230
9CAR7S22023120EB	1200	230	9CAR7S22023120EH	1200	230

#### References with electronic thermostat, 4-40°C, differential less than 0.3°C

Black painted steel body			304 stainless-steel body		
References	Power (W)	Voltage (V)	References	Power (W)	Voltage (V)
9CAV7S12023060EB	600	230	9CAV7S12023060EH	600	230
9CAV7S22023120EB	1200	230	9CAV7S22023120EH	1200	230



# Waterproof industrial radiators

**Industrial electric baseboard heaters, natural convection, width 130mm, IP69K (high pressure, hot water) waterproof grade, IK10 shockproof grade, with 3 or 6 finned heating elements, 1750W and 3500W.**  
**Type 9CB**

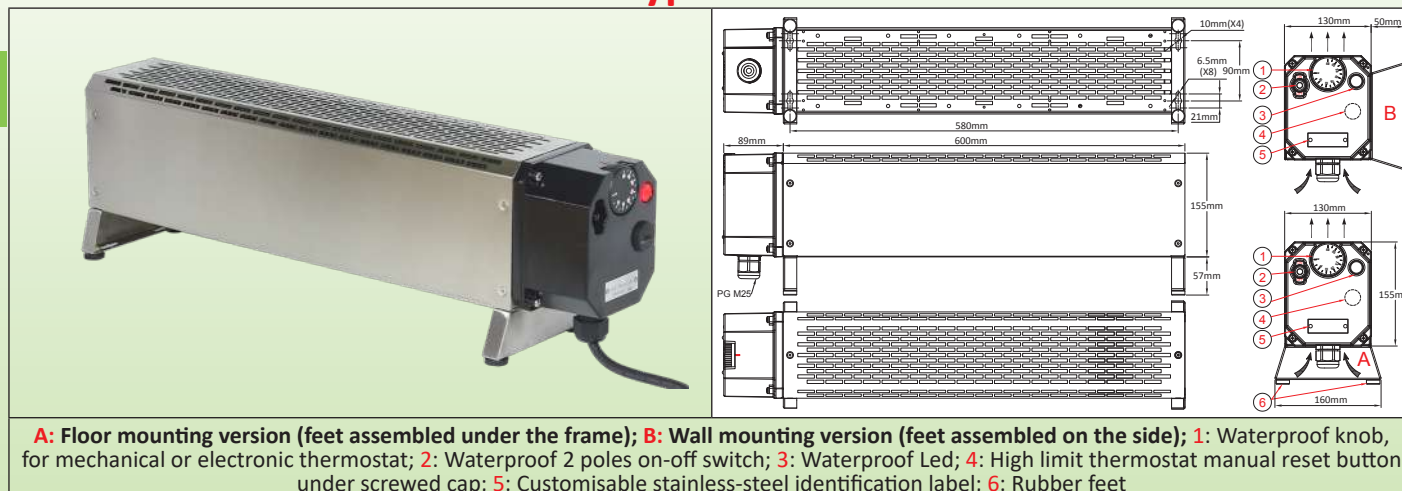

## Main applications

These heavy-duty heaters, are designed for professional, commercial or industrial applications. They are exceptionally sturdy and washable with hot water karcher.

They are equipped with a waterproof control box equipped with a multipole on-off switch, a pilot light, an adjustable control thermostat (mechanical or electronic), a safety limiter, and a tip over switch.

They are not designed for use in hazardous environments.

They exist with painted steel or stainless-steel body.

The main applications are heating of professional workshops, bungalows, cranes cabins, construction equipment, wagons or locomotives cockpit, technical rooms, ovens, containers, dryers, pharmaceutical and food laboratories, breeding premises, military equipment.

## Main features

**Dimensions:** Heating section 600 × 130 × 150mm body (legs not included). Total length 690mm.

**Protection:** Ingress: IP69K, shocks: IK10.

**Heaters:** 3 or 6 finned elements in 304L stainless steel. Fins 25 × 50mm 304 stainless steel. Surface load 2W/cm<sup>2</sup>.

**Frame material:** 0.8mm thick sheet, high strength (Withstands +100kg distributed load), two versions:

- Steel sheet with epoxy paint. Black is standard. Grey Ral 7035 available with MOQ 100p.
- 304 stainless steel sheet.

**Controls:** Located inside an epoxy painted aluminum enclosure, sealable. It includes:

- One adjustable thermostat, mechanical or electronic, range 4 to 40°C.
- One fail safe high limit manual reset thermostat for protection against air outlet obstruction.
- One tip-over switch to protect against heater fail over.

**Electrical connection:** H05RR-F cable, length 2 meters, 3 × 1.5mm<sup>2</sup> (1750W single phase version), 3 × 2.5mm<sup>2</sup> (3500W single phase version) or 5 × 1.5mm<sup>2</sup> (3500W 3 phases version).

**Mounting:** 2 removable legs can be mounted under the frame (floor mounting) or on the side (wall mounting).

**Voltage:** Single phase 230V, 50/60Hz or 400V three phases with neutral.

**Power:** 1750W (3 heating elements) or 3500W (6 heating elements).

**Ambient temperature:** -20 to +60°C.

**Net weight:** 8.3 kg.

References with mechanical thermostat, 4-40°C, differential less than 1°C					
Black painted steel body			304 stainless-steel body		
References	Power (W)	Voltage (V)	References	Power (W)	Voltage (V)
9CBS7T32023175HB	1750	230	9CBS7T32023175H4	1750	230
9CBS7T62023350HB	3500	230	9CBS7T62023350H4	3500	230
9CBT7T62040350HB	3500	3 × 400	9CBT7T62040350H4	3500	3 × 400

References with electronic thermostat, 4-40°C, differential less than 0.3°C					
Black painted steel body			304 stainless-steel body		
References	Power (W)	Voltage (V)	References	Power (W)	Voltage (V)
9CBX7T32023175HB	1750	230	9CBX7T32023175H4	1750	230
9CBX7T62023350HB	3500	230	9CBX7T62023350H4	3500	230
9CBX7T62040350HB	3500	3 × 400	9CBX7T62040350H4	3500	3 × 400



Because of permanent improvement of our products, drawings, descriptions, features used on these data sheets are for guidance only and can be modified without prior advice

# Section 7

## Infrared heaters





Because of permanent improvement of our products, drawings, descriptions, features used on these data sheets are for guidance only and can be modified without prior advice



# Infrared heaters

## High emissivity infrared tubular heaters, with protection housing Type 9MH

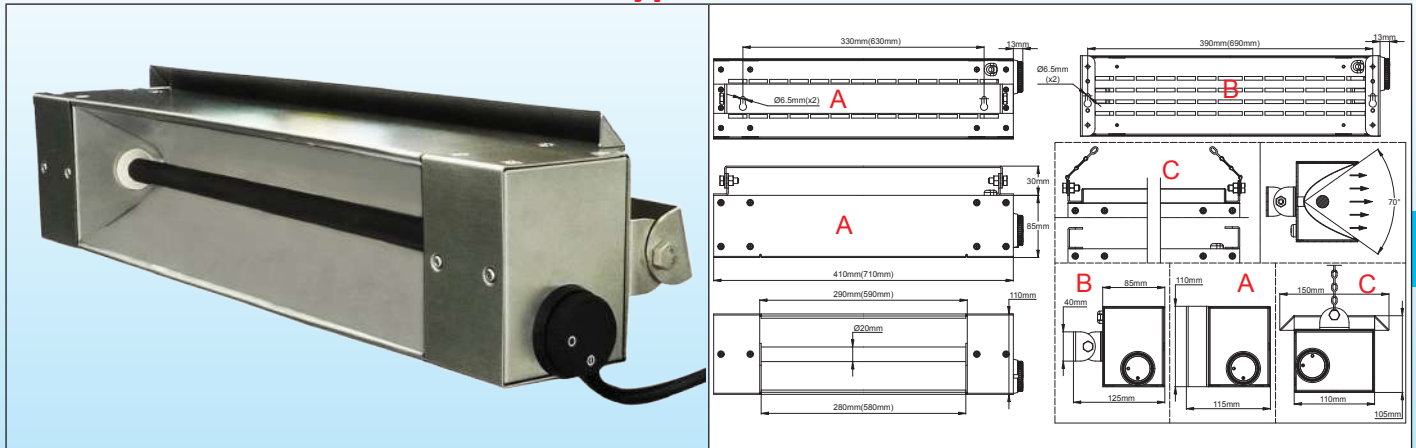

### Applications

They radiate in the infrared between 3 and 6 $\mu$ . They are characterized by an emissivity close to 100% within this range, they show a low surface temperature, a high mechanical strength, and high corrosion resistance.

They are particularly suited for heating, drying, or polymerization of a large part of usual materials where they heat faster than the traditional convection heating.

They can be used for:

- Food warming of products displayed or waiting in fast food and restaurants (See test report in the section 2 of this catalogue)
- Drying at low temperature leather, wood, prints and dyes, paints, ceramic email, food, fish.
- Varnish Polymerization on metal in automotive, appliances and similar industries
- Heating of plastics before forming
- Sterilization of medical devices and equipment or food
- Outdoor ambient warming
- Reheating workstation in workshop
- Heating of stables, poultry.

### Main features

**Radiating tube:** See description on page 5 of section 4

**Housing:** 95 x 110mm, 304 stainless steel, with backside vents, lengths 410mm (16") and 710mm (28"). Many other lengths on request.

**Reflector:** Parabolic, polished aluminum

**Power density:** 3 W/cm<sup>2</sup>. (Other values on request if the wavelength must be modified)

**Warm up time:** less than 5 minutes (From room temperature to stabilization)

**Surface temperature:** 400 to 450°C @ 25°C.

**Protection grid:** On request, as accessory

**Electrical connections:** 2 meters cord, H05VVH2-F, 3 x 1.5mm<sup>2</sup>, 16A grounded euro plug. UL cord on request.

**Mounting:** 3 versions, fixed wall mounting (A), rotating wall mounting (B), hanged (C)

**Switch:** 2 poles on-off switch

**Ingress protection:** IP40 (IP44 for hanged model)

**Voltage:** 230V standard. Other voltages on request (MOQ apply)

**Power adjustment:** See specific devices P11 and P12 of section 4

**Options:**

- Other length, from 280 to 1850mm (11" to 72"), covering the full range of culinary food warmers
- Several tubes grouped side by side on the same surface

### Main References

Overall length (mm)	Power (Watts)	Mounting	References
410	525	Wall mounting, not directional (A)	9MHP290H23052SF1
410	525	Directional wall mounting (B)	9MHP290H23052SR1
410	525	Hanged (C)	9MHP290H23052SS1
710	1100	Wall mounting, not directional (A)	9MHP590H23110LF1
710	1100	Directional wall mounting (B)	9MHP590H23110LR1
710	1100	Hanged (C)	9MHP590H23110LS1



Because of permanent improvement of our products, drawings, descriptions, features used on these data sheets are for guidance only and can be modified without prior advice



Because of permanent improvement of our products, drawings, descriptions, features used on these data sheets are for guidance only and can be modified without prior advice

# Section 8

## Controls for air heating



Because of permanent improvement of our products, drawings, descriptions, features used on these data sheets are for guidance only and can be modified without prior advice



# Controls for air heating

## IP65 fixed setting ambient thermostat, cable gland output, two pilot lights Type Y22

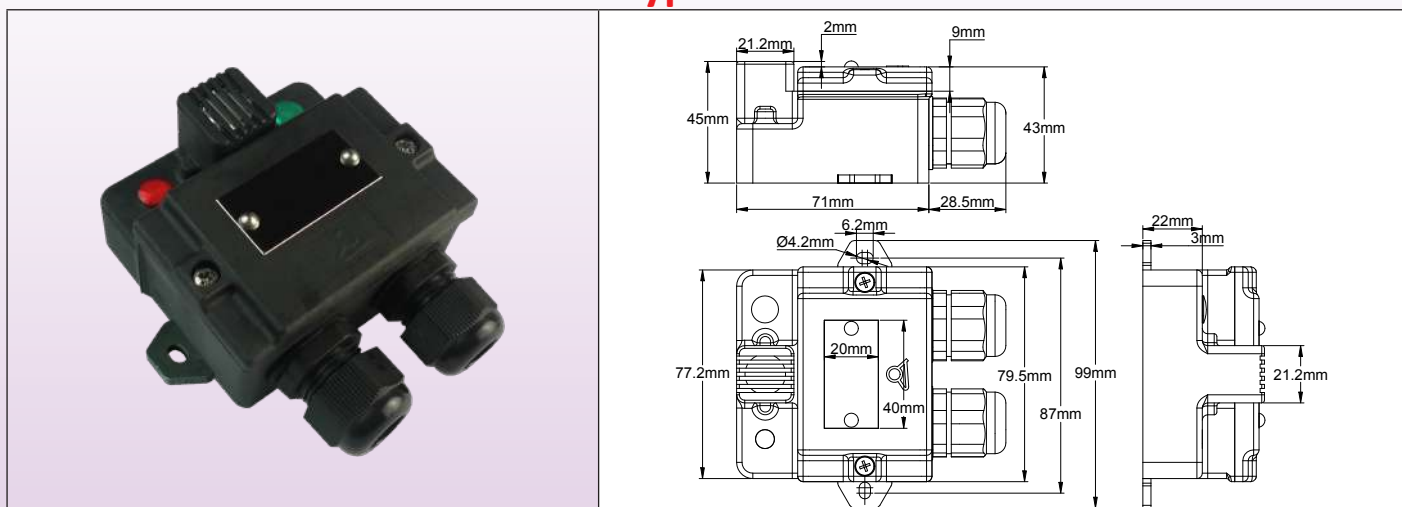

### Applications

Used to sense the ambient temperature indoors or outdoors, and open or close an electrical contact to a predetermined and non-adjustable value. Can be used as an alarm or antifreeze thermostat. In these devices, the thermostat, bimetal disc type, is over-molded, and is thermally insulated from the wall on which it is mounted. Its temperature sensing cup is mechanically protected by a grid. It is located in front of the enclosure to be in an area of natural circulation of air.

### Main features

**Mounting:** Wall, by external side brackets. These tabs can be folded inwards.

**Protection:** IP65 and IK03 (On thermostat guard, IK10 the rest of the housing)

**Material:** ABS-PC black glass-fiber reinforced

**Screws:** Stainless steel, captive

**Output:** 2 Cable glands M20, PA66, IP66, for cable 6 to 12 mm dia.

**Electrical rating:** Single pole, 8 to 16A 250V (100000 cycles). Contact style can be open on rise or close on rise.

**Pilot lights:** Allow to visualize the power supply and thermostat contact position

**Identification:** The cover has a 20x40mm recess for a riveted stainless steel identification plate or a sticker

**Customization:** On request (MOQ apply)

**Connection:** Built in 4mm<sup>2</sup> screw terminal block

#### Options:

- Other calibration temperatures
- Cream color housing
- 115V pilot lights

Open temperature (°C/°F)	Close temperature (°C/°F)	Electrical rating	Main uses	References
8°C/46.4°F	3°C/37.4°F	8A 250V	Freeze protection, switches on defrost device or heating	Y22D9J00806USUSA
10°C/50°F	4°C/39.2°F	10A 250V	Freeze protection, switches on defrost device or heating	Y22D9K01006USUSA
10°C/50°F	4°C/39.2°F	16A 250V	Freeze protection, switches on defrost device or heating	Y22D9L01006USUSA
30°C/86°F	20°C/68°F	10A 250V	Room overheat detection, switches off heating	Y22D9K03006USUSA
20°C/68°F	30°C/86°F	10A 250V	Room overheat detection, switches on alarm (close on rise contact)	Y22D9K02006USUSA
70°C/158°F	60°C/140°F	10A 250V	Fire detection (withstand sprinklers water splash)	Y22D9K07006USUSA





# Controls for air heating

## “Pig tail” bulb room thermostat, IP44 enclosure

### Type Y036G

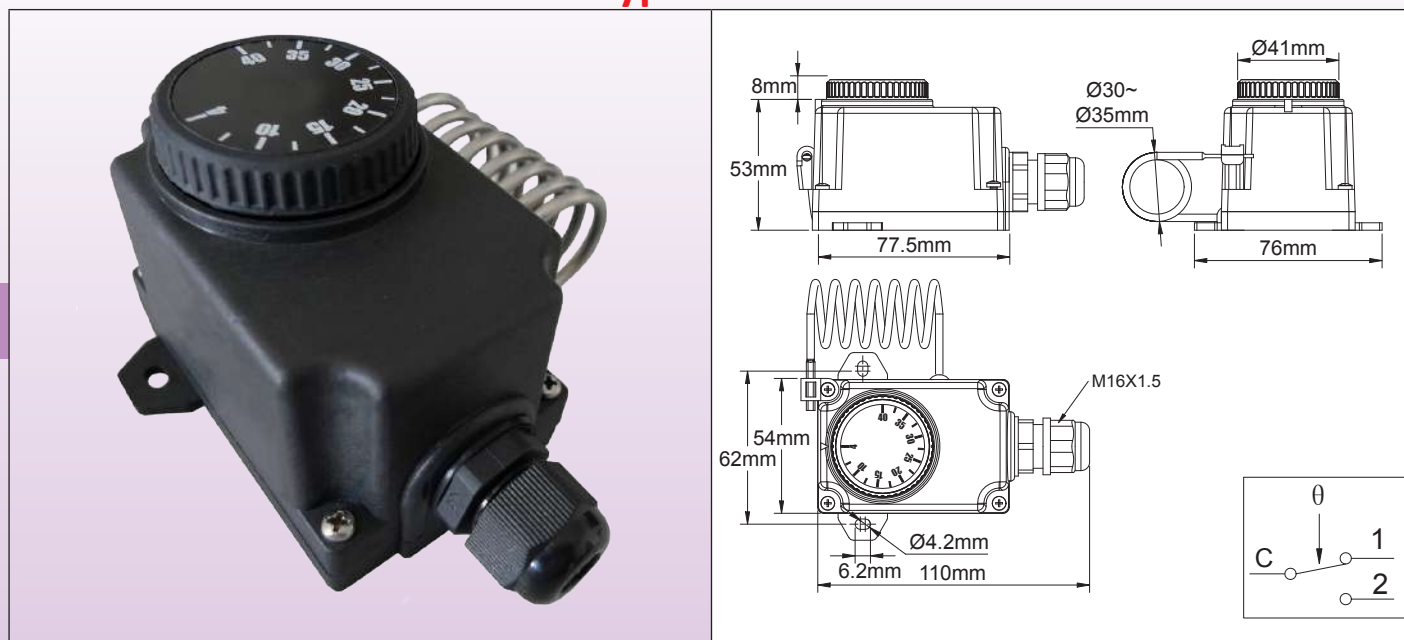

### Applications

Ambient temperature control in professional premises where good protection to liquid splashes or dust is requested. Used in technical rooms, livestock premises, as frost protection or temperature control of heating or ventilation.

### Main features

**Housing:** IP44, 77,5 x 54 x 53 mm, (Knob and cable gland not included), black PC-ABS, UL94V0. High impact and UV resistance. 2 removable wall mounting lugs.

**Electrical input:** M16 cable gland.

**Temperature Adjustment:** With °C printed knob. (°F printed knobs available in option)

**Sensing element:** Liquid filled “pig tail” bulb, mounted on the side of plastic housing

**Adjustment ranges:** 4-40°C (40-105°F). Other temperature ranges available with straight bulb and 1.5m capillary: -35+35°C (-30+95°F), 30-90°C (85-195°F), 30-110°C (90-230°F), 50-200°C (120-390°F), 50-300°C (120-570°F)

**Electrical connections:** Screw terminals

**Mounting:** Wall mounting, by two side lugs with holes for dia. 4mm screws, 62 mm distance.

**Contact:** SPDT

**Electrical rating:**

- Open on temperature rise contact (C-1) 16A(2.6) 250VAC
- Close on temperature rise contact (C-2) 6A(0.6) 250VAC
- Electrical life >100.000 cycles.

### Main references

References	Temperature ranges	Differential	Max temperature on bulb
Y036GA004040QB3J	4-40°C	3±2°C	60°C
Y036GA004040QB3K	40-105°F	5.5±4°F	140°F

### Knob printings

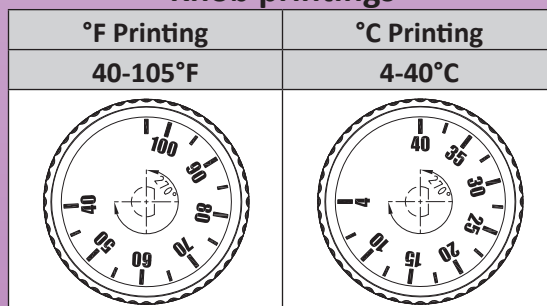

Update 2025/02/25



# Controls for air heating

## Electrical cabinet ambient temperature thermostats, Din Rail mounting Type Y02N

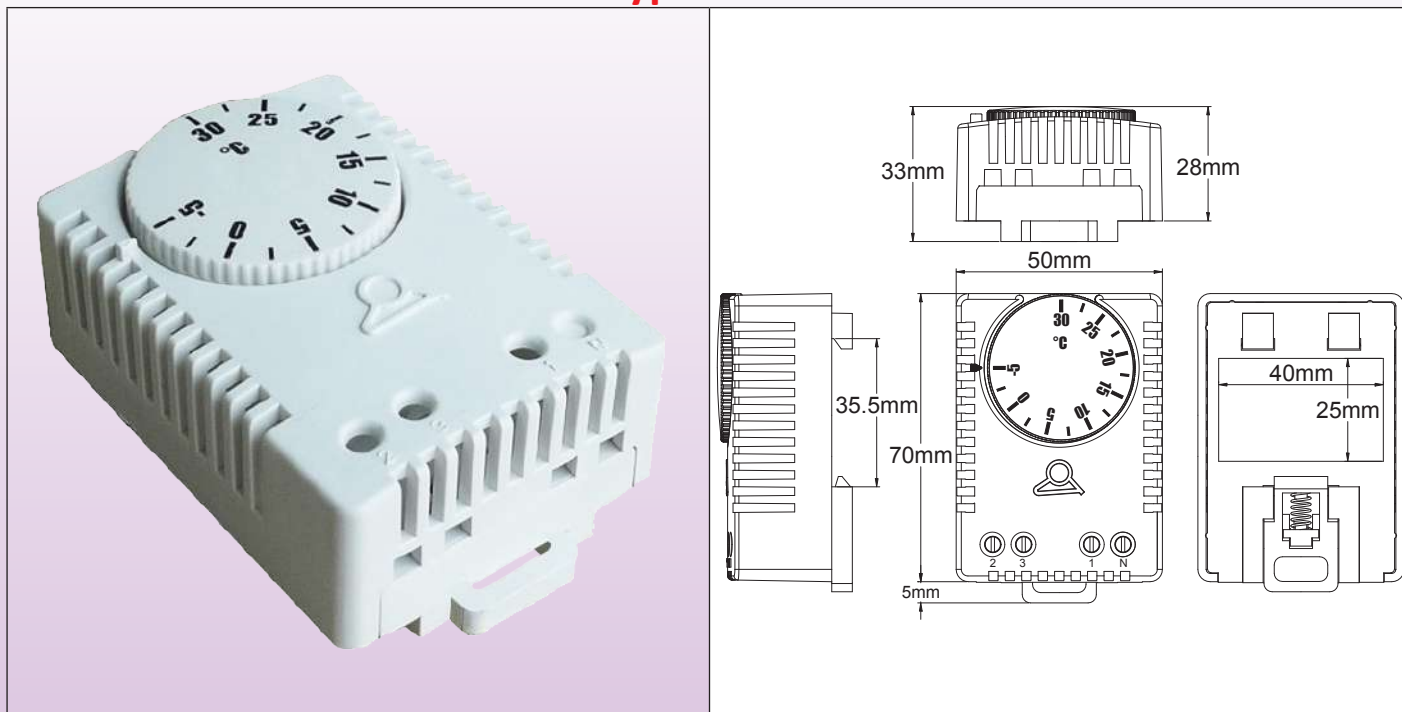

### Main use:

These models have been designed to control the temperature inside electrical cabinets, being mounted on their DIN rail. Their SPDT contact allows their use to control a cabinet heater, a fan, or a cooling system. The anticipation function allows to select 2 different values for the differential.

### Main features

**Temperature ranges:** -10+50°C (15-120°F); -5+30°C (23-86°F); 0+60°C (30-140°F); +20+80°C (70-180°F)

**Set point adjustment:** °C or °F printed knob

**Sensing element:** Bimetal

**Contact type:** Snap-action contact, open or close on temperature rise, 10(2)A 125/250V alt.

**Electrical life:** > 10.000 cycles at rated values

**Contact resistance:** < 10mOhm

**Electrical connection:** 4 screw terminals, for 1.5 mm<sup>2</sup> wires. Neutral terminal must be used only when thermal anticipator is needed (reduced differential)

**Attention:** In standard, thermal anticipator (TA) is wired for use in 230V

**Mounting:** By clip for 35mm DIN rail, EN50022

**Casing:** UL94 V0, PC-ABS, RAL 1010 light grey

**Dimensions:** 70 x 50 x 33 mm

**Operating temperature range:** -20 to +80°C (-4+176°F)

**Ingress protection:** IP30

### Wiring diagram

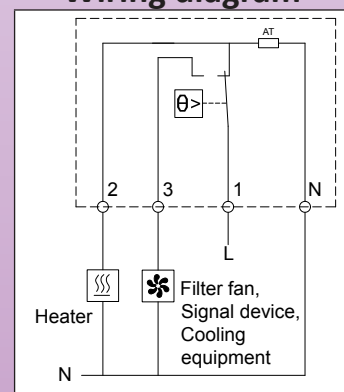

### Main references ( with 230V thermal anticipator)\*

°C types				°F types			
Temperature range (°C)	Differential °C thermal anticipator not connected	Differential °C thermal anticipator connected	References	Temperature range (°F)	Differential °F thermal anticipator not connected	Differential °F thermal anticipator connected	References
-10+50°C	6°C±3°C	4°C±2°C	Y02NAC-10050114L	15-120°F	11±4°F	7±3°F	Y02NAC-10050114P
-5+30°C	6°C±3°C	4°C±2°C	Y02NAC-10050114L	23-86°F	11±4°F	7±3°F	Y02NAC005035114P
0+60°C	6°C±3°C	4°C±2°C	Y02NAC005035114L	30-140°F	11±4°F	7±3°F	Y02NAC000060114P
+20+80°C	6°C±3°C	4°C±2°C	Y02NAC020080114L	70-180°F	11±4°F	7±3°F	Y02NAC020080114P

\* Type with 115V thermal anticipator: Replace 114 in the reference by 115

\* Type with 24V thermal anticipator: Replace 114 in the reference by 112



# Controls for air heating

## Cabinet humidistats, DIN rail mounting Type Q7C

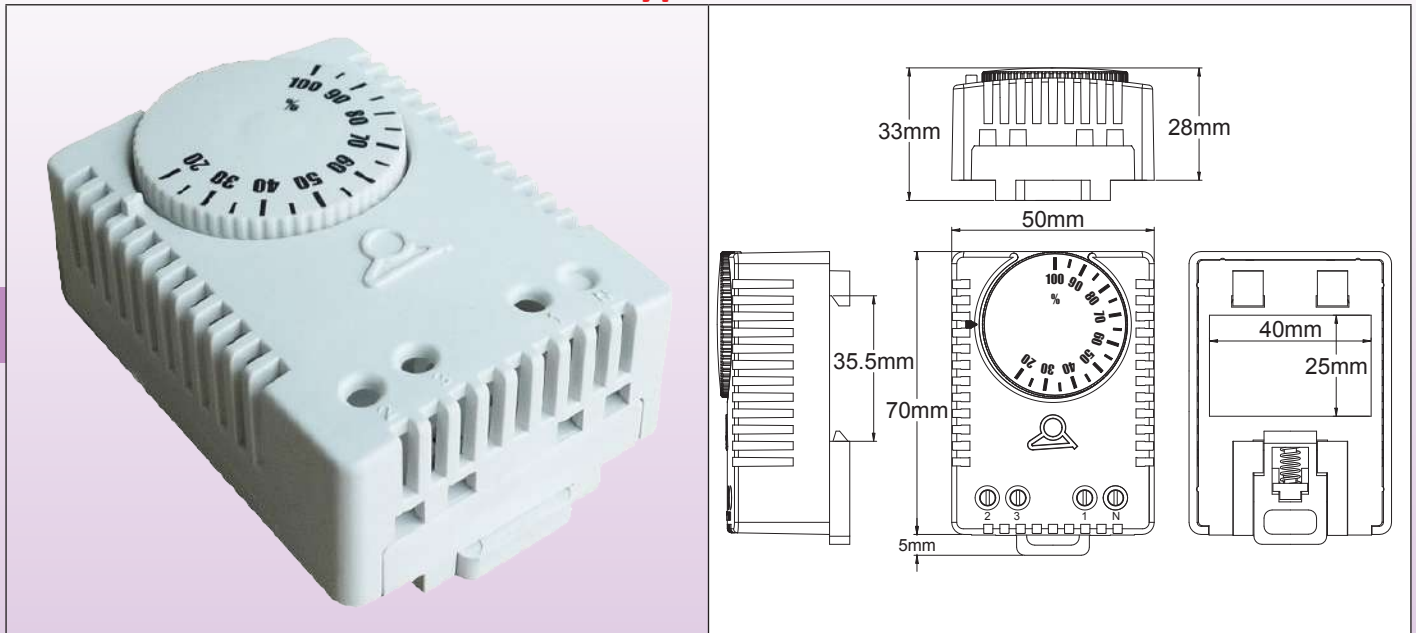

### Applications

Condensation in electrical enclosures and cabinets can be critical for electrical components and safety. This miniature humidistat is designed to switch on a heater or a ventilating fan when the relative humidity raise at dangerous levels, when there is a risk to reach the dew point usually around 65%. It can also be used to switch on humidifiers, dehumidifiers, or other devices. It is designed for mounting on standardized DIN rail.

### Main features

**Humidity sensing element:** Hygroscopic polymer film with special treatment, produced by Ultimheat, ensuring a fast response, long life and high stability

**Setting range:** 35 to 95% RH

**Measuring accuracy:**  $\pm 5\%$  RH

**Differential at 50% RH:** 4% RH ( $\pm 3\%$  RH)

**Measuring medium:** Air, pressure-less, non-aggressive

**Electrical contact:** Silver contacts, SPDT, 10A 250V

**Connection:** 3 screw terminals for 1.5mm<sup>2</sup> wires, max torque 0.5Nm

**Mounting:** Clip for 35mm DIN rail EN50022

**Operating temperature:** 0 to +60°C (+32 to +140°F)

**Storage temperature:** -20 to +70°C (-4 to +158°F)

**Mounting position:** Vertical

**Voltage supply:** The humidistat should be mounted such that there is no buildup of condensate on or in the device. If the voltage supply is higher than 48V there is a risk of voltage arcing in the event of water condensation on the micro-switch or connecting terminals which might destroy the control.

**Ingress protection class:** IP30

**Dimension:** 67x50x 36mm

**Maintenance:** The humidity sensing ribbon is maintenance-free in clean air. Air containing solvent can cause measuring errors and failure, depending on the type and concentration. Deposits such as resin aerosols, lacquer aerosols, smokes, which eventually form a water-repellent film are harmful for the measuring element.

**Reference:** Q7C030100I001R00

### Wiring diagram

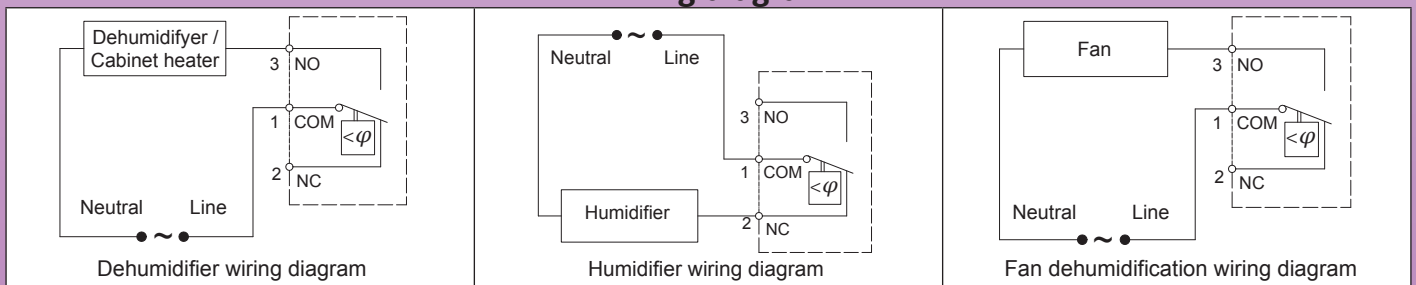



## Controls for air heating

### Electromechanical energy regulators with IP54 protection housing. Type 3AE

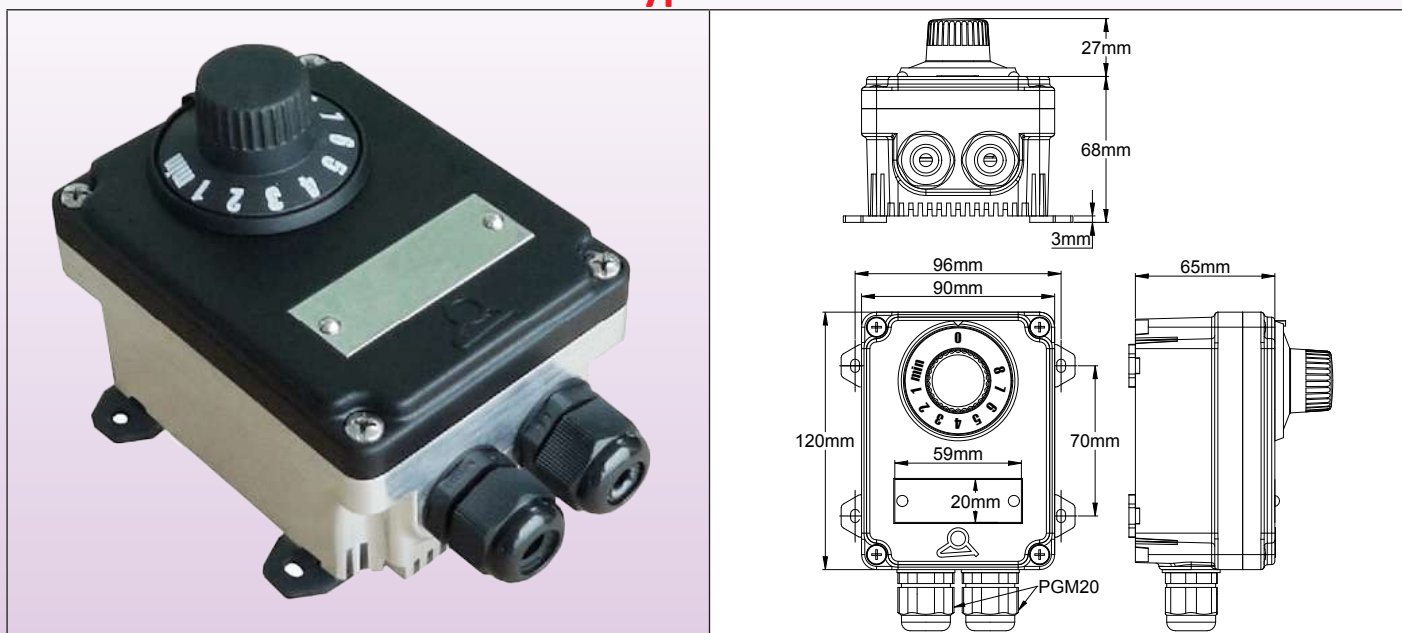

#### Applications

Cost saver solution for power control of high thermal inertia heating elements (thermal cycling device), used in professional and commercial premises, barns, stables, hen houses, poultry breeding.

#### Main features

**Set point display:** Knob graduated from min to 8.

Min position provides about 5% of the power, and 8 about 100%, non-linear curve.

Zero position provides full disconnection of line and neutral.

**Output:** Cyclic open and close of an electrical contact with a cycle time of 20 to 30s for use high thermal inertia heating elements or convection heating. Not to be used on low thermal inertia medium and long infrared emitters.

**Electrical rating:** 12A 250V

**Enclosure:** 120 x 70 x 65mm, rear in aluminum with cooling fins, front in black PA66.

**Protection class:** IP54

**Mounting:** Wall mounting, with 4 removable legs, 70 x 96mm distance

**Internal Connection:** 4 ways 6mm<sup>2</sup>, ceramic terminal block. (2 power input terminals, 2 power output terminals ). 2 earth terminals.

**Cables Input-Output:** By 2 cable glands, M20, polyamide.

**Residual voltage at off:** 0 V

**Leakage current at off:** 0 mA

**Ambient temperature:** -20 to +70°C

**Insulation Voltage:** 1500VAC

**Insulation resistance:** 50MΩ/500VDC

**Important:**

- Install this unit in a line with an appropriate circuit breaker.

- Not to be used for electric motor speed control

#### Main references

Reference	Voltage	Reference	Voltage
3AER102TF024V	24	3AER101TF230V	230
3AER102TF048V	48	3AER104TF400V	400
3AER105TF110V	110		



# Controls for air heating

## Fixed setting infrared heating thermostats Type Y23

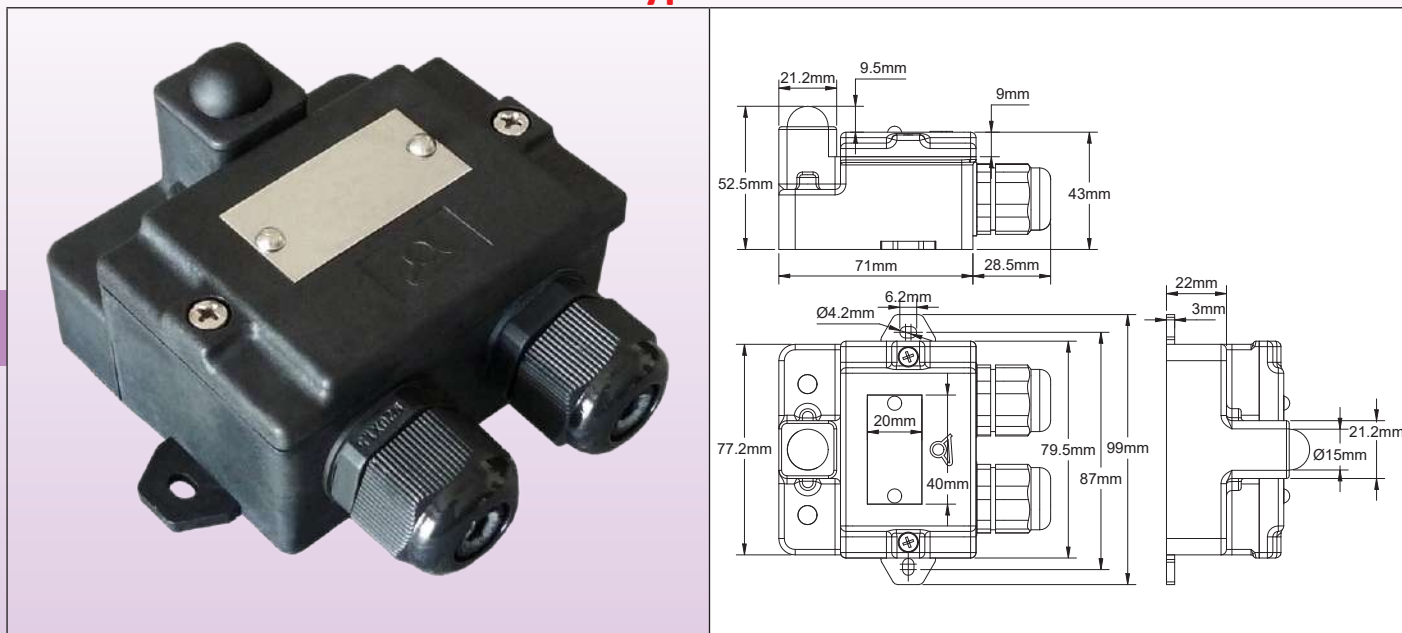

### Applications

Fixed setting disc thermostat, located inside hemispherical black-body. The disc thermostat senses the heat produced by infrared absorption in the black-body it is located in.

For use in professional and commercial premises, industrial and livestock buildings.

### Main features

The correct measurement of the radiated temperature requires installing the device in a location where it is exposed to direct radiation. In these enclosures, the thermostat is thermally insulated from the wall on which it is mounted, and senses the resulting temperature of the absorption by the black body added to the room ambient temperature.

**Enclosure:** 77.2 x 71 x 52.5mm, black PC-ABS

**Protection class:** IP65

**Mounting:** Wall mounting, with 2 removable legs, 87mm distance

**Internal Connection:** 6 ways 4mm<sup>2</sup>, ceramic terminal block. (2 power input terminals, 2 power output terminals, 2 earth terminals).

**Cables Input-Output:** By 2 cable glands, M20, polyamide.

**Electric rating:** 15A 250VAC

**Set point temperature:** See references table. Other temperatures on request (MOQ apply)

**Ambient temperature:** -20 to +70°C

**Insulation Voltage:** 2000VAC

**Insulation resistance:** 500MΩ/500VDC

### Main references

Reference	°C		°F	
	Open temperature	Close temperature	Open temperature	Close temperature
Y23D7J03308C1C10	33	25	91.4	77
Y23D7Q04511C1C10	34*	45*	93.2	113
Y23D7J04010C1C10	40	30	104	86
Y23D7J05010C1C10	50	40	122	104
Y23D7J05510C1C10	55	45	131	113
Y23D7J06010C1C10	60	50	140	122
Y23D7J07010C1C10	70	60	158	140

\* Close on temperature rise contact.

Because of permanent improvement of our products, drawings, descriptions, features used on these data sheets are for guidance only and can be modified without prior advice

Update 2025/02/25





# Controls for air heating

## Bulb and capillary room thermostat for infrared heating, IP44 enclosure Type 038G

Because of permanent improvement of our products, drawings, descriptions, features used on these data sheets are for guidance only and can be modified without prior advice

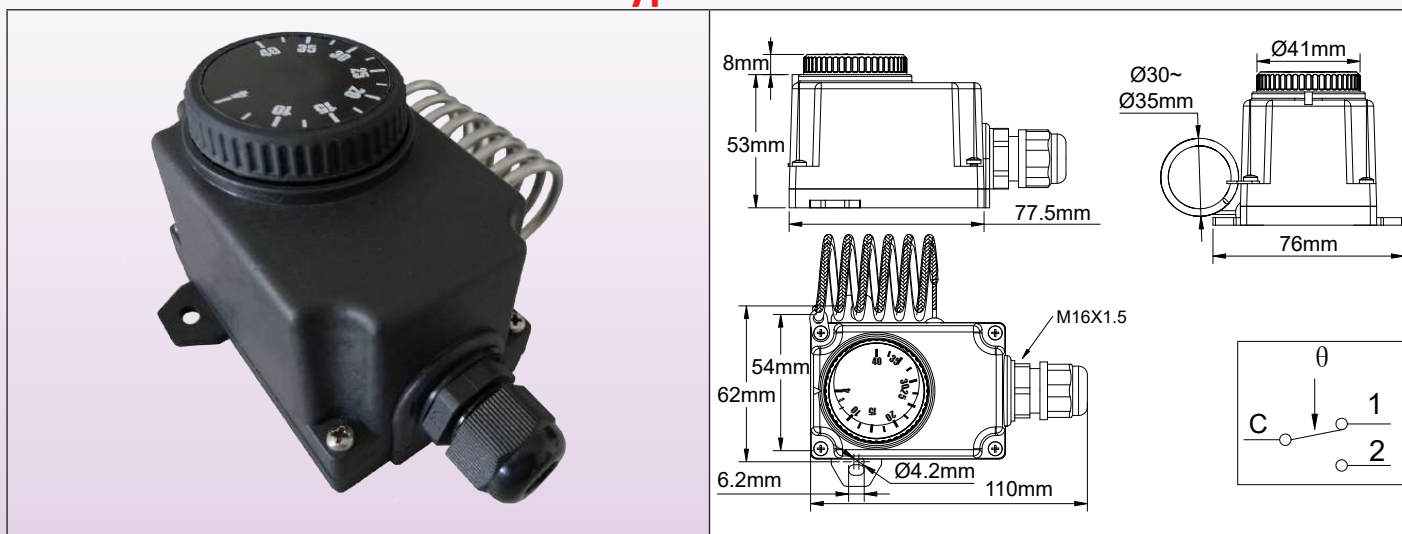

### Applications

**These coiled bulb adjustable thermostats have a specially treated bulb to be infra-red sensitive.**

The correct measurement of the radiated temperature requires installing the device in a location where it is exposed to direct radiation. In these devices, the thermostat senses the resulting temperature of the infrared absorption by the black bulb added to the room ambient temperature.

### Main features

**Housing:** IP44, 77,5 x 54 x 53 mm, (Knob and cable gland not included), black PC-ABS, UL94V0. High impact and UV resistance. 2 removable wall mounting lugs.

**Electrical input:** M16 cable gland.

**Temperature Adjustment:** With °C printed knob.

°F printed knobs available in option

**Sensing element:** Liquid filled helicoidal bulb, mounted on the side of plastic housing

**Adjustment ranges:** 4-40°C (40-105°F).

**Electrical connections:** Screw terminals

**Mounting:** Wall mounting, by two side lugs with holes for dia. 4 mm screws, 62 mm distance.

**Contact:** SPDT

**Electrical rating:**

- Open on temperature rise contact (C-1) 16A(2.6) 250VAC

- Close on temperature rise contact (C-2) 6A(0.6) 250VAC

- Electrical life >100.000 cycles.

### Main references

°C		°F		Bulb diameter (D, mm)	Bulb length (L, mm)	Differential °C (°F)	Max temperature on bulb °C (°F)
References (°C)	Temperature ranges (°C)	References (°F)	Temperature ranges (°F)				
Y038GA004040QO3J	4-40°C	Y038GA004040AA3K	40-105°F	Dia 3	Dia 35 x 40mm coiled	3±2 (5.5±4)	60 (140)
Y038GA004040AO6J	4-40°C	Y038GA004040AO6K	40-105°F	6	140 straight	3±2 (5.5±4)	60 (140)

Also available with 0-10 printed knob or crescent printed knob

### Knob printings

°F Printing	°C Printing	Decimal printing	Crescent printing
40-105°F	4-40°C	0-10	4-40°C

Update 2025/02/25





## Controls for air heating

### Electronic power control for infrared heaters, 10 to 20A. Miniature IP65 housing with built in heat exchanger Type 3AS

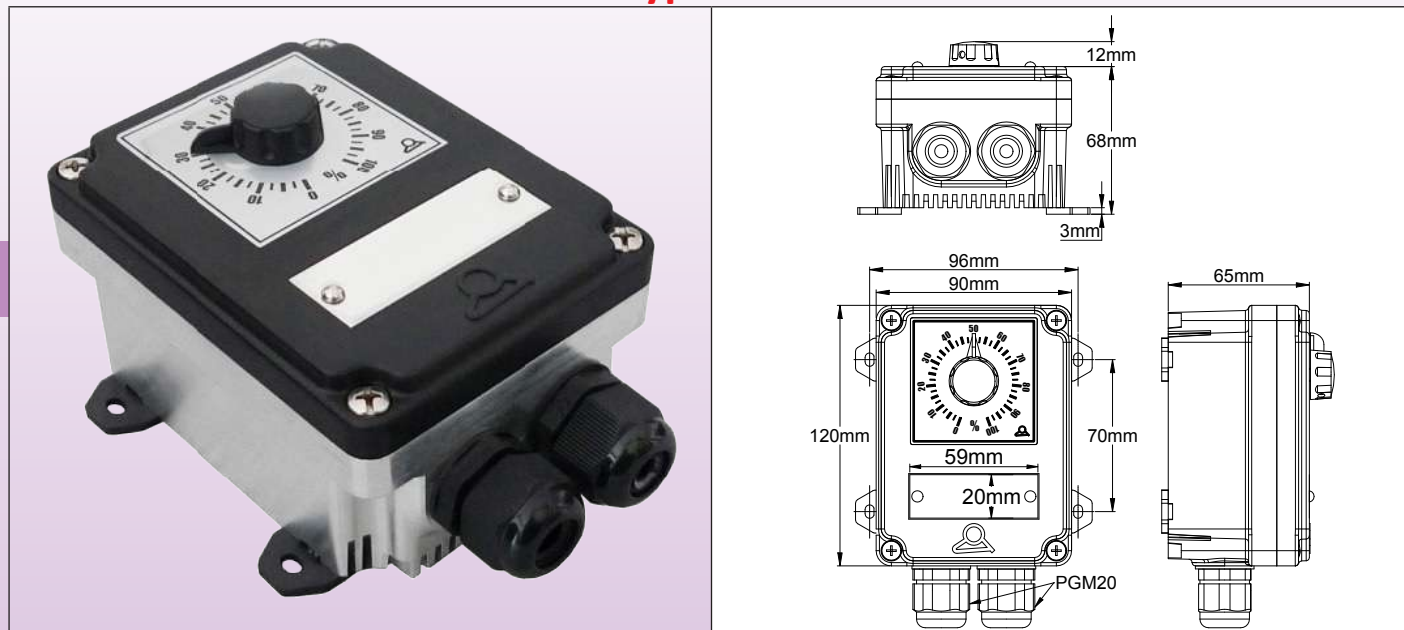

#### Applications

Solid state relay power control, for metering power of infrared emitters between 5% and 100% of their nominal value. For use in professional and commercial premises, industrial and livestock buildings.

#### Main features

**Set point display:** Potentiometer graduated in % of power.

**Output:** Zero crossing (no radio interferences), with 10ms cycle time, for use on low thermal inertia medium and long infrared emitters.

**Enclosure:** 120 x 70 x 65mm, rear in aluminum with cooling fins, front in black PA66.

**Protection class:** IP54

**Mounting:** Wall mounting, with 4 removable legs, 70 x 96mm distance

**Internal Connection:** 4 ways 6mm<sup>2</sup>, ceramic terminal block. (2 power input terminals, 2 power output terminals). 2 earth terminals.

**Cable Input-Output:** By 2 cable glands, M20, polyamide.

**Residual voltage at off:** ≤ 1.5V

**Leakage current at off:** ≤ 4mA

**Ambient temperature:** -20 to +70°C

**Insulation Voltage:** 2000VAC

**Insulation resistance:** 500MΩ/500VDC

#### Important:

- Like all solid state relays, this device dissipates about 0.5% of the power by the Joule effect.
- Install this unit in a line with a power switch and an appropriate circuit breaker.
- Not to be used for electric motor speed control

#### References

Reference	Max. power	Voltage	Reference	Max. power	Voltage
3ASN30100110	10A	220-240V	3ASN30700110	10A	380-400V
3ASN30100120	20A	220-240V	3ASN30700120	20A	380-400V



## Controls for air heating

### Electronic power control for infrared heaters, 25 to 60A. IP65 housing with built in heat exchanger Type 3AY

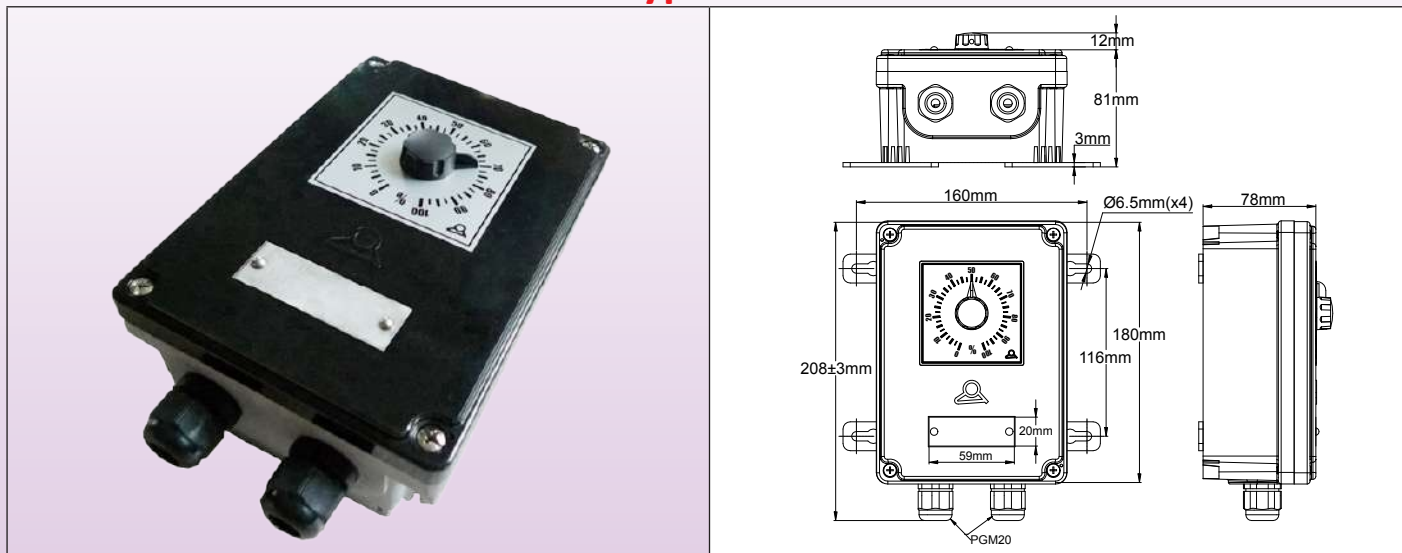

#### Applications

Solid state relay power control, for metering power of infrared emitters between 5% and 100% of their nominal value. For use in professional and commercial premises, industrial and livestock buildings.

#### Main features

**Set point display:** Potentiometer graduated in % of power.

**Output:** Zero crossing, (no radio interference), with 10ms cycle time, for use on low thermal inertia medium and long infrared emitters.

**Enclosure:** 180x130x78mm, rear in aluminum with cooling fins, front in black PA66.

**Protection class:** IP65, with waterproof gasket on adjustment potentiometer shaft

**Mounting:** Wall mounting, with 4 removable legs, 70 x 96mm distance

**Internal Connection:** 4 ways 6mm<sup>2</sup>, ceramic terminal block. (2 power input terminals, 2 power output terminals). 2 earth terminals.

**Cable Input-Output:** By 2 cable glands, M20, polyamide.

**Overheat protection:** Built in high limit disc thermostat, automatic reset, opens at 80°C.

**2 pole on-off switch:** Available on 25A 220-240 models only (does not allow power adjustment between 0 and 20%)

**Residual voltage at off:** ≤ 1.5V

**Leakage current at off:** ≤ 4mA

**Ambient temperature:** -20 to +70°C

**Isolation Voltage:** 2000VAC

**Insulation resistance:** 500MΩ/500VDC

#### Important:

- Like all solid state relays, this device dissipates about 0.5% of the power by the Joule effect.
- Install this unit in a line with a power switch and an appropriate circuit breaker.
- Not to be used for electric motor speed control

#### Main references

Reference	Max. power	Voltage	Reference	Max. power	Voltage
3AYM30100125*	25A	220-240V	3AYN30700125	25A	380-400V
3AYN30100125	25A	220-240V	3AYN30700140	40A	380-400V
3AYN30100140	40A	220-240V	3AYN30700160	60A	380-400V
3AYN30100160	60A	220-240V			

\* Model with 2 pole on-off switch

Because of permanent improvement of our products, drawings, descriptions, features used on these data sheets are for guidance only and can be modified without prior advice



Because of permanent improvement of our products, drawings, descriptions, features used on these data sheets are for guidance only and can be modified without prior advice

---

Contact us

[www.ultimheat.com](http://www.ultimheat.com)



# ULTIMHEAT

---

## HEAT & CONTROLS



Catalogues collection on  
[www.ultimheat.com](http://www.ultimheat.com)

**Electromechanical components & OEM heating sub-assemblies manufacturer**

- Mechanical thermostats
- Mechanical safeties single & three poles
- ATEX thermostats & safeties
- Flow through liquid heaters
- Immersion heaters
- Heating elements for air and liquid
- Connection blocks
- Housings for corrosive environments
- Flow switches
- Level switches
- Pressure switches and air switches
- Fusible links and fire detection mechanisms
- Tracing equipment
- **Taylor made solutions**



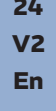

**24**  
**v2**  
**En**

**AIR HEATING SOLUTIONS**